

CROMPTON INSTRUMENTS LED SYNCHROSCOPES

APPLICABLE UP TO 480V AC



**CLEARLY INDICATES SYNCHRONISING
STATE WITH RELAY OUTPUT AND REAL-TIME
FEEDBACK FOR BETTER MONITORING**

APPLICATIONS

- Switchgear Panels

RELEVANT STANDARDS AND TEST REPORTS

- IEC 61010

KEY FEATURES

- Clear Synchronising indication
- Relay output for remote indication

TE Connectivity's (TE) Crompton Instruments LED Synchrosopes measure and display the frequency difference of two power sources. Monitoring the display allows the user to connect two synchronized power systems.

The LED indication gives real-time feedback on the synchronisation state. When the synchronised state is achieved, the indicator stays in the synchronising position.

The LED indication gives real-time feedback on the synchronisation state with relay output for systems integration. Dead bus monitoring is also available, as an option, combined with the Voltage and phase monitoring.

The 244-14H/G synchroscope is based on a microcontroller, which interprets the input signals and displays the phase and voltage information on a series of light emitting diodes (LED's)

Twenty-four red LED's are arranged in a ring simulating the traditional 360° analogue movement. Only one LED is lit at any one time indicating the phase difference between the busbar (BUS) and generator (GEN) signals.

The unit will operate correctly at any frequency within its range. The voltage levels of the two input signals are continuously measured and compared with the user adjustable voltage difference setting. If the measured difference is outside the allowable range, the ring of LED's will be extinguished, and the red GEN LED will be lit. If the voltage difference is within range the green GEN LED will be lit and the ring of LED's will indicate the phase relationship.

ORDERING INFORMATION

Model	Voltage	Operation
244-14HG-J-01	59-77V AC	Synchro check relay, Voltage Difference and Dead Bus
244-14HG-L-01	100-120V AC	
244-14HG-M-01	220-240V AC	
244-14HG-H-01	380-480V AC	
244-14GG-J-01	59-77V AC	Synchro check relay, and Voltage Difference
244-14GG-L-01	100-120V AC	
244-14GG-M-01	220-240V AC	
244-14GG-H-01	380-480V AC	

DIMENSIONAL INFORMATION & CONNECTION DIAGRAM

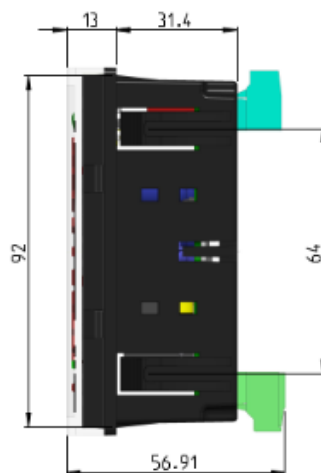
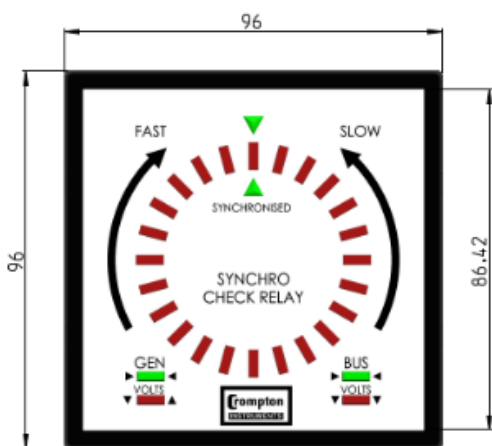
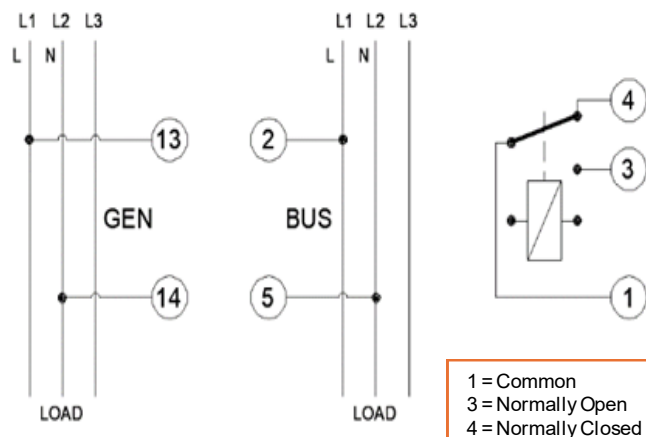

TECHNICAL SPECIFICATIONS

Parameters	
Nominal Voltage	± 10% of range
Nominal Frequency	45 / 65 Hz
Operating Position	Panel Mounted (Vertical)
Accuracy	1%
Overload	1.2x range max, continuous, 2x for 5 secs
Relay Output Type	Single Pole changeover
Relay Output Rating	250 V, 5 A AC resistive
Operating Temperature	-20°C to +55°C (-4°F to 131°F)
Storage Temperature	-30°C to +70°C (-22°F to 158°F)
Humidity	95% RH (non-condensing)
Insulation Between Circuits	2.2 kV
Insulation to Case	4 kV
Overvoltage Category	III
Pollution Degree	II
Enclosure Integrity	UL94-V0
Enclosure Style	DIN 96
Case Material	Polycarbonate
Ingress Protection	IP54 (with gasket)
Electrical Connections	Cage clamp, Plug / Socket
Mounting	Snap-In
Dimensions	96 x 96 x 65 mm
Weight	200 g
Burden	< 4 VA
Phase Difference	Adjustable 0-20 Degrees
Time Delay	Adjustable 0-2.5 Seconds

Learn more: [TE.com/energy](https://www.te.com/energy)

© 2024 TE Connectivity. All Rights Reserved. EPP-4293-DDS-05/24

TE, TE Connectivity, TE connectivity (logo), EVERY CONNECTION COUNTS, are trademarks owned or licensed by TE Connectivity. Other logos, product and company names mentioned herein may be trademarks of their respective owners. While TE has made every reasonable effort to ensure the accuracy of the information in this brochure, TE does not guarantee that it is error-free, nor does TE make any other representation, warranty or guarantee that the information is accurate, correct, reliable or current. TE reserves the right to make any adjustments to the information contained herein at any time without notice. TE Connectivity's obligations shall only be as set forth in TE Connectivity's Standard Terms and Conditions of Sale for this product and in no case will TE Connectivity be liable for any incidental, indirect or consequential damages arising out of the sale, resale, use or misuse of the product. TE expressly disclaims all implied warranties regarding the information contained herein, including, but not limited to, any implied warranties of merchantability or fitness for a particular purpose. The dimensions, specifications, and/or information contained herein are for reference purposes only and are subject to change without notice. Consult TE for the latest dimensions, specifications, and/or information. Users of TE Connectivity products should make their own evaluation to determine the suitability of each such product for the specific application.

Connect with us:

[crompton-instruments.com](https://www.crompton-instruments.com)