

# Operating Manual

## DRR-100-3P DIN RAIL MOUNTED THREE PHASE ENERGY METER





# DIRECT CONNECTED ENERGY METER

## Installation & Operating Instructions

Section	Contents
1.	Introduction
2.	LCD Display
	2.1 Introduction
	2.2 LCD Display Symbols and Indications
	2.2.1 Tariff Input Indication
	2.2.2 SO/Tariff Input Output Indication
	2.2.3 Communication Indication
	2.2.4 Tariff Energy Indication
	2.2.5 Load Graph Indication
	2.3 Start-up Screens
	2.4 Measurement Screens Navigation Map
	2.5 Setup Screens Navigation Map
3.	Programming
	3.1 Password Protection
	3.2 Menu Selection
	3.2.1 System Parameter Selection
	3.2.1.1 System Type
	3.2.1.2 Demand Integration Time
	3.2.1.3 Auto Scrolling
	3.2.1.4 Quit System Parameters
	3.2.2 Communication Parameter Selection
	3.2.2.1 Address Setting
	3.2.2.2 Baud Rate
	3.2.2.3 Parity
	3.2.2.4 Quit Communication Parameters
	3.2.3 Output Parameter Selection
	3.2.3.1 SO Output 1 Selection
	3.2.3.1.1 SO 1 or 2 Selection Menu
	3.2.3.1.1.1 None Output
	3.2.3.1.1.2 Pulse Output
	3.2.3.1.1.3 Parameter Selection

- 3.2.3.1.1.4 Pulse Duration
- 3.2.3.1.1.5 Pulse Rate
- 3.2.3.1.1.6 Quit SO Output Selection

- 3.2.3.2 SO 2 Selection
- 3.2.3.3 Quit Output Parameters

- 3.2.4 Display Parameters
  - 3.2.4.1 Backlit
  - 3.2.4.2 Display Test Screen
  - 3.2.4.3 Quit Display Parameters
- 3.2.5 Reset Parameters
  - 3.2.5.1 Partial Energy Reset
  - 3.2.5.2 Max Demand Reset
  - 3.2.5.3 Setup Parameter Reset
  - 3.2.5.4 Code Reset
  - 3.2.5.5 Reset All
  - 3.2.5.6 Quit Reset Parameters

- 3.2.6 Setup Quit

- 4. Tariff Input
  - 4.1 Tariff Input and Tariff Selection
- 5. SO Output
  - 5.1 Pulse Output
- 6. RS485 (MODBUS) Output
  - 6.1 Accessing 3X and 4X Register for Reading Measured Values
  - 6.2 Accessing 4X Register for Reading & Writing Settings
  - 6.3 User Assignable Modbus Registers
- 7. MBUS
- 8. Installation
  - 8.1 EMC Installation Requirements
  - 8.2 Case Dimensions
  - 8.3 Nameplate
  - 8.4 Wiring
  - 8.5 Fusing
  - 8.6 Sealing
- 9. Errors and Diagnostics
- 10. Connection Diagrams
  - 10.1 Connection of L1, L2, L3 and LN (In and out)
  - 10.2 Connection for SO Output / Tariff Input / RS 485
- 11. Safety Instructions
- 12. Specifications

# 1. INTRODUCTION

The Direct Connected Energy Meter is a DIN rail-mounted digital device designed for precise bidirectional measurement of Active, Reactive, and Apparent Energy. It is suitable for industrial, commercial, and residential applications requiring reliable electrical energy metering. In addition to energy measurement, the meter provides accurate readings of key electrical parameters including Voltage, Current, Frequency, Active Power, Reactive Power, Apparent Power, and Power Factor across both single-phase and three-phase networks. Built on advanced microcontroller technology, the meter supports various network configurations such as 3-Phase 4-Wire, 3-Phase 3-Wire, and 1-Phase 2-Wire systems. It is capable of direct current measurement up to 100 A. The device features a bright, intuitive LCD display for real-time parameter visualization. It includes pulse outputs and an impulse LED for energy monitoring, as well as tariff counters that can be configured via tariff input. For remote monitoring and integration with energy management systems, the Direct Connect model supports industry-standard communication protocols including MODBUS RTU and MBUS.



## 2. LCD Display

### 2.1. Introduction

The meter presents over 100 measurement parameters, including Total Energy, Tariff-based Energy, Partial Energy, and Per-Phase Energy values. It also displays key electrical metrics such as Maximum Demand, Voltage, Current, Frequency, Active Power, Reactive Power, Apparent Power, and Power Factor—each on dedicated, clearly structured screens. The user interface is designed for intuitive navigation using three front-panel keys. The main menu highlights the most critical and frequently accessed parameters. Users can scroll through these using the up and down keys, while the right key provides access to additional related data for each selected parameter. For energy-related metrics, tariff counters are available. Pressing the right key further reveals per-phase energy counters, which can be individually browsed using the up and down keys. Similarly, for system parameters such as Voltage, Current, and Power, the right key opens per-phase views, allowing detailed inspection of each phase. Refer to Table 1 for a comprehensive list of all measurement parameters available on the display and accessible via MODBUS/MBUS communication protocols.

### 2.2. LCD Display Symbols and Indications

The meter features a high-contrast LCD display with bold seven-segment digits and bright white backlighting, ensuring clear visibility of measurement parameters in various lighting conditions. The display includes intuitive symbols, unit indicators, and a load graph to enhance readability and facilitate straightforward on-site configuration. Continuous visual indicators are provided for key statuses, including current reversal, communication activity, tariff input status, and pulse output status. Users can choose between automatic or manual scrolling modes for navigating measurement screens, allowing flexible access to data based on preference or operational needs.

#### 2.2.1. Tariff Input Indication

The meter has 2 Tariff Input for 4 tariff for selection of active tariff registers. The status of Tariff Input is continuously available on screen via symbols as shown below:

**DI**  **1** Input at 1 is present, input at 2 is absent.

**DI**  Input at 1 and 2 is absent.

### 2.2.2. SO Output Indication

The meter has two opto-isolated pulse outputs that can be configured for any one of the Active (Total /Import /Export) or Reactive (Total/Import/Export) Energy parameter. The status of SO output is indicated on LCD as shown below:



Pulse output at SO1.



Pulse output at SO2.

### 2.2.3. Communication Indication

The meter provides optional communication based on MODBUS / MBUS protocol for remote data acquisition of measurement data and configuration. If meter is properly communicating with host then it is indicated by symbol as shown:



This symbol indicates that the meter is communicating.

### 2.2.4. Tariff Energies Indication

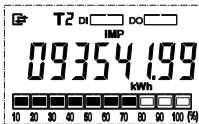

This Instrument comes with 4 Tariff based on Tariff Input 1 and Tariff Input 2 (TA & TB). In the image given here, it indicates that the instrument is currently displaying the selected energy parameter (Import Active Energy) of Tariff 2.

These Tariff energies are available on display, refer Measurement Parameter Navigation Map.

### 2.2.5. Load Graph Indication



The meter continuously monitors and indicates the system current as percentage of max current, allowing user to easily monitor the load as shown.

**TABLE 1 : Measurement Parameters:**

Parameter No.	Parameters	On Display			On Modbus		
		3P 4W	3P 3W	1P 2W	3P 4W	3P 3W	1P 2W
1	Import Active Energy	✓	✓	✓	✓	✓	✓
2	Export Active Energy	✓	✓	✓	✓	✓	✓
3	Total Active Energy	✓	✓	✓	✓	✓	✓
4	Import Reactive Energy	✓	✓	✓	✓	✓	✓
5	Export Reactive Energy	✓	✓	✓	✓	✓	✓
6	Total Reactive Energy	✓	✓	✓	✓	✓	✓
7	Total Apparent Energy	✓	✓	✓	✓	✓	✓
8	L1, L2, L3 Import Active Energy	✓	✗	✗	✓	✗	✗
9	L1, L2, L3 Export Active Energy	✓	✗	✗	✓	✗	✗
10	L1, L2, L3 Total Active Energy	✓	✗	✗	✓	✗	✗
11	L1, L2, L3 Import Reactive Energy	✓	✗	✗	✓	✗	✗
12	L1, L2, L3 Export Reactive Energy	✓	✗	✗	✓	✗	✗
13	L1, L2, L3 Total Reactive Energy	✓	✗	✗	✓	✗	✗
14	L1, L2, L3 Total Apparent Energy	✓	✗	✗	✓	✗	✗
15	Partial Import Active Energy	✓	✓	✓	✓	✓	✓
16	Partial Export Active Energy	✓	✓	✓	✓	✓	✓
17	Partial Total Active Energy	✓	✓	✓	✓	✓	✓
18	Partial Import Reactive Energy	✓	✓	✓	✓	✓	✓
19	Partial Export Reactive Energy	✓	✓	✓	✓	✓	✓
20	Partial Total Reactive Energy	✓	✓	✓	✓	✓	✓
21	Partial Total Apparent Energy	✓	✓	✓	✓	✓	✓
22	T1 Import Active Energy	✓	✓	✓	✓	✓	✓
23	T1 Export Active Energy	✓	✓	✓	✓	✓	✓
24	T1 Total Active Energy	✓	✓	✓	✓	✓	✓
25	T1 Import Reactive Energy	✓	✓	✓	✓	✓	✓
26	T1 Export Reactive Energy	✓	✓	✓	✓	✓	✓
27	T1 Total Reactive Energy	✓	✓	✓	✓	✓	✓
28	T1 Total Apparent Energy	✓	✓	✓	✓	✓	✓
29	T1 Partial Import Active Energy	✓	✓	✓	✓	✓	✓
30	T1 Partial Export Active Energy	✓	✓	✓	✓	✓	✓
31	T1 Partial Import Reactive Energy	✓	✓	✓	✓	✓	✓

**TABLE 1 : Measurement Parameters (contd.):**

Parameter No.	Parameters	On Display			On Modbus		
		3P 4W	3P 3W	1P 2W	3P 4W	3P 3W	1P 2W
32	T1 Partial Export Reactive Energy	✓	✓	✓	✓	✓	✓
33	T2 Import Active Energy	✓	✓	✓	✓	✓	✓
34	T2 Export Active Energy	✓	✓	✓	✓	✓	✓
35	T2 Total Active Energy	✓	✓	✓	✓	✓	✓
36	T2 Import Reactive Energy	✓	✓	✓	✓	✓	✓
37	T2 Export Reactive Energy	✓	✓	✓	✓	✓	✓
38	T2 Total Reactive Energy	✓	✓	✓	✓	✓	✓
39	T2 Total Apparent Energy	✓	✓	✓	✓	✓	✓
40	T2 Partial Import Active Energy	✓	✓	✓	✓	✓	✓
41	T2 Partial Export Active Energy	✓	✓	✓	✓	✓	✓
42	T2 Partial Import Reactive Energy	✓	✓	✓	✓	✓	✓
43	T2 Partial Export Reactive Energy	✓	✓	✓	✓	✓	✓
44	T3 Import Active Energy	✓	✓	✓	✓	✓	✓
45	T3 Export Active Energy	✓	✓	✓	✓	✓	✓
46	T3 Total Active Energy	✓	✓	✓	✓	✓	✓
47	T3 Import Reactive Energy	✓	✓	✓	✓	✓	✓
48	T3 Export Reactive Energy	✓	✓	✓	✓	✓	✓
49	T3 Total Reactive Energy	✓	✓	✓	✓	✓	✓
50	T3 Total Apparent Energy	✓	✓	✓	✓	✓	✓
51	T3 Partial Import Active Energy	✓	✓	✓	✓	✓	✓
52	T3 Partial Export Active Energy	✓	✓	✓	✓	✓	✓
53	T3 Partial Import Reactive Energy	✓	✓	✓	✓	✓	✓
54	T3 Partial Export Reactive Energy	✓	✓	✓	✓	✓	✓
55	T4 Import Active Energy	✓	✓	✓	✓	✓	✓
56	T4 Export Active Energy	✓	✓	✓	✓	✓	✓
57	T4 Total Active Energy	✓	✓	✓	✓	✓	✓
58	T4 Import Reactive Energy	✓	✓	✓	✓	✓	✓
59	T4 Export Reactive Energy	✓	✓	✓	✓	✓	✓
60	T4 Total Reactive Energy	✓	✓	✓	✓	✓	✓
61	T4 Total Apparent Energy	✓	✓	✓	✓	✓	✓
62	T4 Partial Import Active Energy	✓	✓	✓	✓	✓	✓

**TABLE 1 : Measurement Parameters (contd.):**

Parameter No.	Parameters	On Display			On Modbus		
		3P 4W	3P 3W	1P 2W	3P 4W	3P 3W	1P 2W
63	T4 Partial Export Active Energy	✓	✓	✓	✓	✓	✓
64	T4 Partial Import Reactive Energy	✓	✓	✓	✓	✓	✓
65	T4 Partial Export Reactive Energy	✓	✓	✓	✓	✓	✓
66	System Current Max Demand	✓	✓	✓	✓	✓	✓
67	System kW Max Demand	✓	✓	✓	✓	✓	✓
68	System kVAR Max Demand	✓	✓	✓	✓	✓	✓
69	System kVA Max Demand	✓	✓	✓	✓	✓	✓
70	System Import kW Max Demand	✓	✓	✓	✓	✓	✓
71	System Export kW Max Demand	✓	✓	✓	✓	✓	✓
72	System Import kVAR Max Demand	✓	✓	✓	✓	✓	✓
73	System Export kVAR Max Demand	✓	✓	✓	✓	✓	✓
74	System L1, L2, L3 Current Max Demand	✓	✓	✗	✓	✓	✗
75	System Voltage	✓	✓	✓	✓	✓	✓
76	L1, L2, L3 Voltage	✓	✗	✗	✓	✗	✗
77	System Voltage L12	✓	✓	✗	✓	✓	✗
78	System Voltage L23	✓	✓	✗	✓	✓	✗
79	System Voltage L31	✓	✓	✗	✓	✓	✗
80	System Current	✓	✓	✓	✓	✓	✓
81	L1, L2, L3 Current	✓	✓	✗	✓	✓	✗
82	Frequency	✓	✓	✓	✓	✓	✓
83	System Active Power	✓	✓	✓	✓	✓	✓
84	L1, L2, L3 Active Power	✓	✗	✗	✓	✗	✗
85	System Reactive Power	✓	✓	✓	✓	✓	✓
86	L1, L2, L3 Reactive Power	✓	✗	✗	✓	✗	✗
87	System Apparent Power	✓	✓	✓	✓	✓	✓
88	L1, L2, L3 Apparent Power	✓	✗	✗	✓	✗	✗
89	System Power Factor	✓	✓	✓	✓	✓	✓
90	L1, L2, L3 Power Factor	✓	✗	✗	✓	✗	✗

**TABLE 1 : Measurement Parameters (contd.):**

Parameter No.	Parameters	On Display			On Modbus		
		3P 4W	3P 3W	1P 2W	3P 4W	3P 3W	1P 2W
91	System Phase Angle	✓	✓	✓	✓	✓	✓
92	L1, L2, L3 Phase Angle	✓	✗	✗	✓	✗	✗
93	System Voltage THD	✓	✓	✓	✓	✓	✓
94	L1, L2, L3 Voltage THD	✓	✗	✗	✓	✗	✗
95	System Current THD	✓	✓	✓	✓	✓	✓
96	L1, L2, L3 Current THD	✓	✗	✗	✓	✗	✗
97	System Current Demand	✗	✗	✗	✓	✓	✓
98	System kW Demand	✗	✗	✗	✓	✓	✓
99	System kVAR Demand	✗	✗	✗	✓	✓	✓
100	System kVA Demand	✗	✗	✗	✓	✓	✓
101	System Import kW Demand	✗	✗	✗	✓	✓	✓
102	System Export kW Demand	✗	✗	✗	✓	✓	✓
103	System Import kVAR Demand	✗	✗	✗	✓	✓	✓
104	System Export kVAR Demand	✗	✗	✗	✓	✓	✓
105	System L1, L2, L3 Current Demand	✗	✗	✗	✓	✓	✗

### 2.3.Start-up Screens example

The meter display a sequence of screens upon every start-up procedure. The first screen is all segment glow screen which ensures that all symbols glow properly. The subsequent screens aids in software identification of the meter as shown below:



All segment glow screen



CRC-1 screen

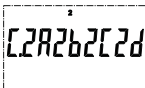

CRC-2 screen

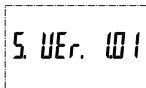

Software Version screen

## 2.4. Measurement Parameters Screen Navigation Map

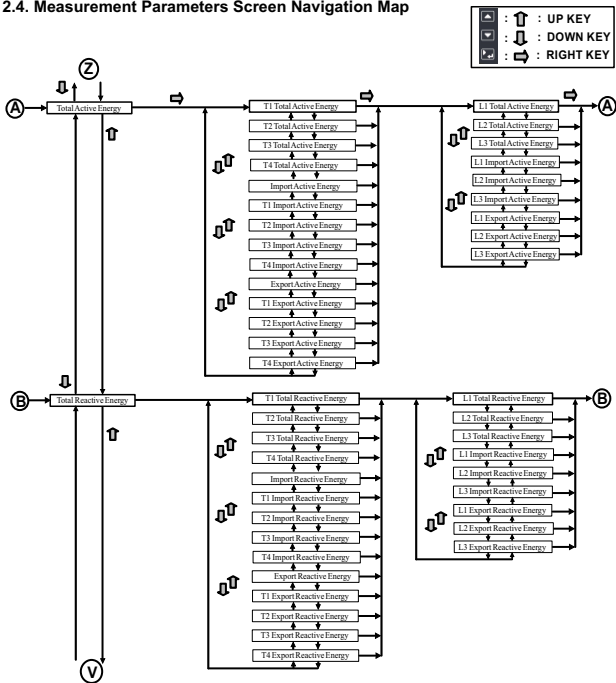

Measurement Parameters Screens Navigation Map cont...

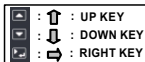
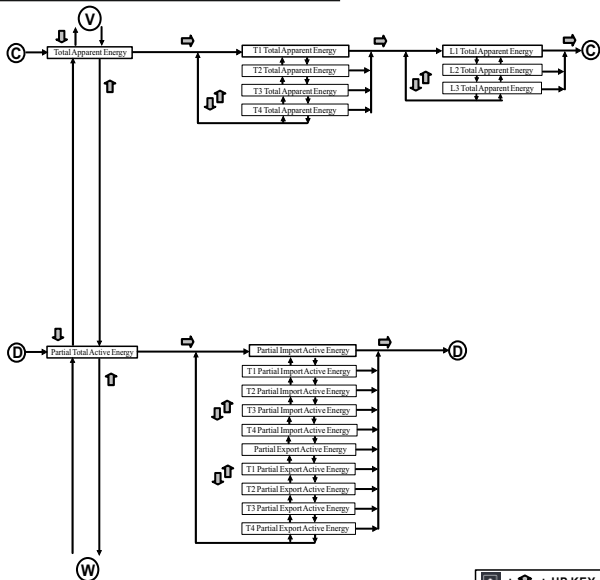

Measurement Parameters Screens Navigation Map cont...

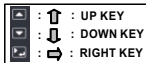
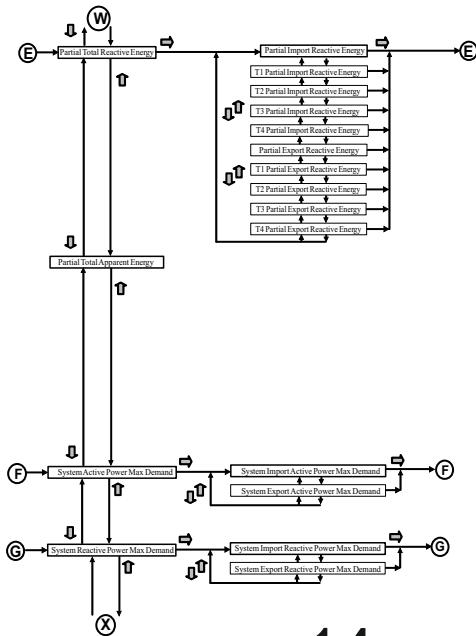

Measurement Parameters Screens Navigation Map cont...

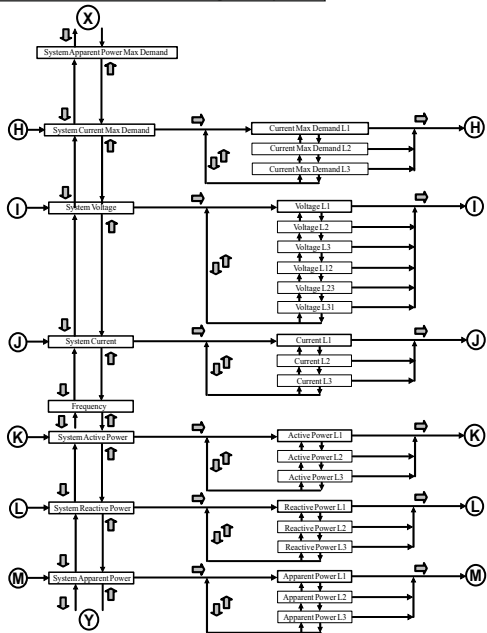

Measurement Parameters Screens Navigation Map cont...

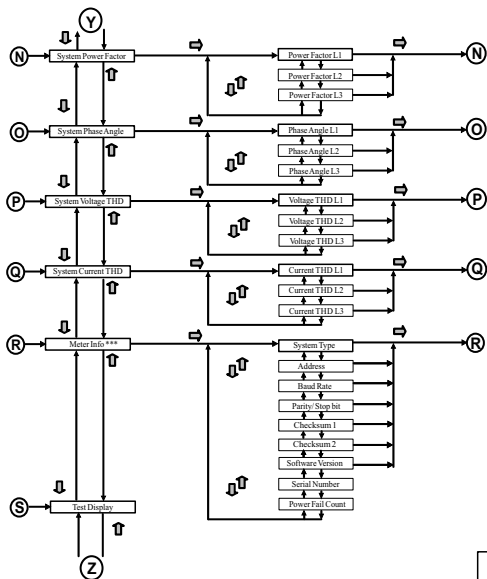

\*\*\*The Screens are shown in the following page with their brief description.

## Meter Info Screens:

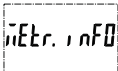

METR. INFO

This screens helps the user to know some basic parameters without being able to edit them. The Parameters are : Address, Baud Rate, Parity/Stop Bit, checksum 1, checksum 2, Software Version, Serial Number, and Power Fail counts.

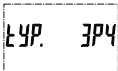

TYP. 3P4

This screen will show the system type

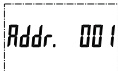

Addr. 001

This screens will show the device address of the unit.



bAud 96

This screens will show the set baud rate of the unit.

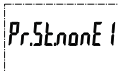

Pr.Stop 1

This screens will show the parity and stop bit.



C.1R 1b 1C 1d

This screens shows the Checksum 1



C2R2b2C2d

This screens shows the Checksum 2



S. VER. 101

This screens shows the software version of the unit.

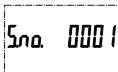

S.no. 0001

This screens will show the serial number of the unit. The screen alternates to display 10 digit S.no.

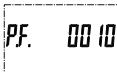

PF. 0010

This screens will show that how many times the unit has been switched off.

## 2.5. Setup Parameters Screens Navigation Map

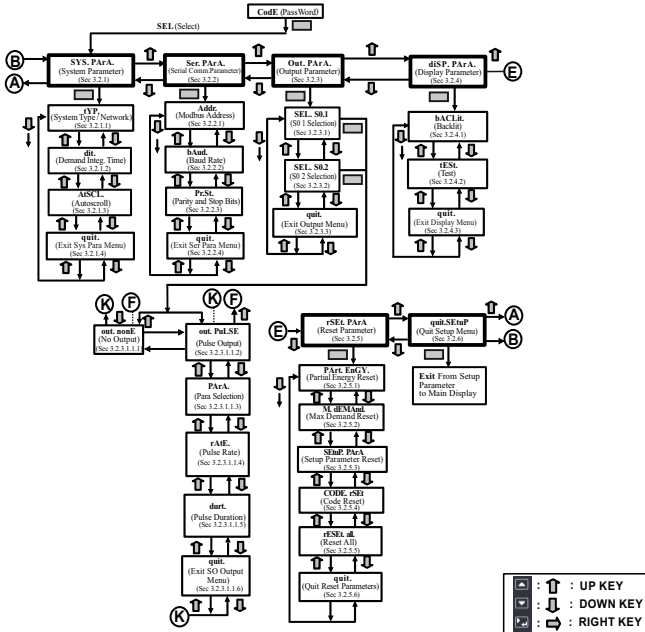

### 3. PROGRAMMING

The following sections comprise step by step procedures for configuring the Energy Meter according to individual user requirements. To access the set-up screens press and hold "Enter" key for 5 seconds. This will take the user into the Password Protection Entry Stage (Section 3.1).

#### 3.1. Password Protection

Password protection can be enabled to prevent unauthorized access to set-up screens. Password protection is enabled by selecting a four digit number other than 0000, setting a password of 0000 disables the password protection.

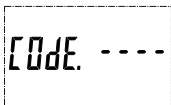

Enter Password, prompt for first digit. Press the "▲" key to scroll the value of first digit from 0 through to 9, the value rolls back from 9 round to 0 and "▼" key to scroll the value of first digit from 9 through to 0, the value rolls back from 0 round to 9.

Press the "◀" key to advance to next digit.



In special cases where the Password is "0000" pressing the "◀" key when prompted for the first digit advances to the password accepted screen and then pressing the "◀" key again makes the set-up screens accessible to the user.

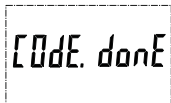

But instead of pressing the "◀" key, if "▲" or "▼" key is pressed, the user is taken to the "New/change Password" entry stage.

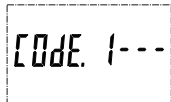

Enter Password, first digit entered, prompt for second digit..

Press the "▲" key to scroll the value of first digit from 0 through to 9, the value rolls back from 9 round to 0 and "▼" key to scroll the value of first digit from 9 through to 0, the value rolls back from 0 round to 9.

Press the "◀" key to advance to next digit.



CODE. 12--

Enter Password, second digit entered, prompt for third digit.

Press the "▲" key to scroll the value of first digit from 0 through to 9, the value rolls back from 9 round to 0 and "▼" key to scroll the value of first digit from 9 through to 0, the value rolls back from 0 round to 9.

Press the "←" key to advance to next digit.



CODE. 123-

Enter Password, third digit entered, prompt for fourth digit .

Press the "▲" key to scroll the value of first digit from 0 through to 9, the value rolls back from 9 round to 0 and "▼" key to scroll the value of first digit from 9 through to 0, the value rolls back from 0 round to 9.

Press the "←" key to advance to verification of the password.



CODE. 1234

Enter Password, fourth digit entered, awaiting verification of the password.

### Password confirmed.

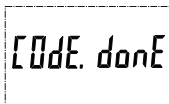

CODE. done

Pressing the "←" key advances to the Menu selection (setup menu) screen (see Section 3.2).

## Password Incorrect.

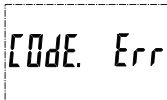

The unit has not accepted the Password entered  
The unit automatically returns to the Enter Password stage.

## New / Change Password



Prompting for first digit.

Press the "▲" and "▼" keys to scroll the value of first digit from 0 through to 9 and from 9 through to 0, respectively with digit roll around feature.

Pressing the "←" key advances the operation to the next digit and sets the first digit, in this case to "2".



New/ Change Password, first digit entered, prompting for second digit.

Press the "▲" and "▼" keys to scroll the value of second digit from 0 through to 9 and from 9 through to 0, respectively with digit roll around feature.

Pressing the "←" key advances the operation to the next digit and sets the second digit, in this case to "1".

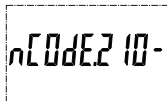

New/ Change Password, second digit entered, prompting for third digit.

Press the "▲" and "▼" keys to scroll the value of second digit from 0 through to 9 and from 9 through to 0, respectively with digit roll around feature.



Pressing the "←" key to advance the operation to the next digit and sets the third digit, in this case to "4".



New/ Change Password, third digit entered, prompting for fourth digit. .

Press the "▲" and "▼" keys to scroll the value of second digit from 0 through to 9 and from 9 through to 0, respectively with digit roll around feature.

Pressing the "←" key to advance the confirmation screen and sets the fourth digit, in this case to "3".

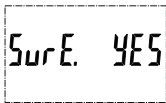

Pressing the "←" key advances to the "New Password confirmed" screen.

### New Password confirmed

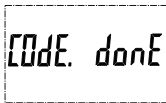

Pressing the "←" key advances to the Menu selection screen (see Section 3.2).

## 3.2. Menu selection

### 3.2.1. System Parameter Selection



This screen is used to select system Parameters like "System Type", "Demand Time Integration (DIT)" and "Autoscroll".

Pressing the "←" key allows the user to set different system parameters (see Section 3.2.1.1 to 3.2.1.3).

Pressing the "▲" key advances to the "Communication Parameter Selection" screen (see Section 3.2.2) and pressing "▼" key advances to the "Quit Setup" Screen (see Section 3.2.7).

### 3.2.2. Communication Parameter Selection



This screen is used to select the different communication parameters like "Address selection", "Parity & Stop Bits", "Baud Rate", etc.

Pressing the "◀" key allows the user to set different Communication parameters (see Section 3.2.2.1 to 3.2.2.3).

Pressing the "▲" key advances to the "Output Parameter Selection" screen (see section 3.2.3) and pressing "▼" key advances to the "System Parameter Selection" screen (see Section 3.2.1).

### 3.2.3. Output Parameter Selection



This screen will allow the user to select and configure SO Output parameters like pulse rate, duration and pulse parameter.

Pressing the "◀" key allows the user to select and configure the output options (see Section 3.2.3.1).

Pressing "▲" key advances to the "Display Parameter Selection" screen (see Section 3.2.4) and pressing "▼" key advances to "Communication Parameter Selection" screen (see Section 3.2.2).

### 3.2.4. Display Parameter Selection



This screen will allow the user to access different features like "Backlit" and "Display Test Screen".

Pressing the "◀" key allows the user to select and configure the features (see Section 3.2.5.1 to Section 3.2.5.2).

Pressing the "▲" key advances to "Reset Parameter Selection" screen (see Section 3.2.6) and pressing "▼" key advances to "Tariff Parameters Selection" screen (see Section 3.2.4).

### 3.2.5. Reset Parameter Selection



This screen is used to reset different parameters like partial energy, maximum demand etc..

Pressing the "←" key allows the user to reset different parameters (see Section 3.2.6.1 to Section 3.2.6.4 ).

Pressing the "▲" key advances to the "Quit Setup Screens" screen (see Section 3.2.7) and pressing "▼" key advances to "Display Parameter Selection" screen (see Section 3.2.5).

### 3.2.6. Quit Setup Screens

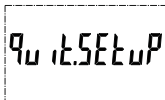

This screen is used to quit setup menu and return back to measurement screens.

Pressing the "←" key allows the user to quit setup menu.

Pressing the "▲" key advances to the "System Parameter Selection" screen (see Section 3.2.1) and pressing "▼" key advances to "Reset Parameter Selection" screen (see Section 3.2.6).

### 3.2.1. System Parameter Selection

#### 3.2.1.1. System Type

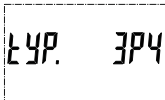

This screen is used to set the system type.

Pressing the "←" key advances into the system type edit mode and then pressing the "▲" and "▼" key scrolls through the options available:

The user can select values 3P4W, 3P3W, 1P2W. System type "3P3W" for 3 Phase 3 Wire, "3P4W" for 3 Phase 4 Wire system & "1P2W" for 1 Phase 2 Wire System.

Pressing the "←" key accepts the present value and returns to the "System Type" menu (see Section 3.2.1.1).

Pressing "▲" key advances to the "Demand Time Integration" screen (see Section 3.2.1.2) and pressing the "▼" key advances to "Quit System Parameters" screen (see Section 3.2.1.4).

**NOTE : Default value is set to 3P4W i.e. for 3 Phase 4 Wire System.**

### 3.2.1.2. Demand Integration Time

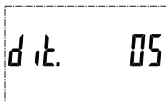

This screen is used to set the period over which current and power readings are to be integrated. The Unit of displayed value is **minutes**.

Pressing the "←" key enables editing and pressing keys "▲" and "▼" allows scrolling to select desired value. The user can select values 1, 5, 10, 15, 30, 60 minutes.

Once the desired value is selected, pressing " ← " key confirms the selection, followed by "Demand Integration Time" screen (see Section 3.2.1.2).

Pressing the " ▲ " key advances to "Auto Scrolling" screen (see Section 3.2.1.3) and pressing the " ▼ " key advances to "System Type" screen (see Section 3.2.1.1).

**NOTE: Default value is set to '5' i.e. 5 min.**

### 3.2.1.3. Auto Scrolling



This screen allows user to enable auto screen scrolling.

Pressing " ▲ " key accepts the present status and advance to the "Quit System Parameter" screen (see Section 3.2.1.4). Similarly, pressing " ▼ " key accepts the present status and advances to the "Demand Integration Time" screen (see Section 3.2.1.2).

Pressing the " ← " key allows editing and keys " ▲ " and " ▼ " allows the user to select either 'ON' to enable autoscroll and 'OFF' to disable auto-scroll.

Pressing " ← " key selects the status displayed and returns to "Autoscroll" screen (see Section 3.2.1.3).

**NOTE: Default value is set to 'OFF'.**

### 3.2.1.4. Quit System Parameters

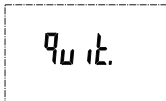

This screen allows user to Exit from System Parameter selection setup.

Pressing the " ▲ " key advances to "System Type" screen (see Section 3.2.1.1). Similarly, pressing the " ▼ " key advances to "Auto Scrolling" screen (see Section 3.2.1.3). Pressing the " ← " key advances to "System Parameter Selection" screen (see Section 3.2.1).

## 3.2.2. Communication Parameter Selection

### 3.2.2.1. Address Setting



This screen allows the user to set RS 485 address for the meter.

The allowable range of addresses for MODBUS is 1 to 247 and for MBUS the address range is 1 to 250 .

Press "←" to enter into edit mode, blinking of digits indicates that editing is enabled.

Press the "▲" and "▼" keys to scroll the value of the first digit. Press the "←" key to advance to next digit.

Similarly, enter second and third digits of address. After entering third digit, pressing "←" key confirms the selection and shows "Address Setting" screen (see Section 3.2.2.1).

Press "▲" key to advance to "RS 485 Baud Rate" screen (see Section 3.2.2.2) or press the "▼" key to advance to the "Quit Communication Parameters" screen (see Section 3.2.2.4).

**NOTE : The default setting is '001'.**

### 3.2.2.2. Baud Rate



This screen allows the user to set Baud Rate. The values displayed on screen are in kbps.

Pressing the "←" key advances to the "Baud Rate Edit" mode and "▲" & "▼" keys scrolls the value through **4.8, 9.6, 19.2, 38.4 and 57.6** kbps for MODBUS and **0.3, 0.6, 1.2, 2.4, 4.8 and 9.6** kbps for MBUS .

Pressing "▲" key accepts the present value and advance to the "Parity and Stop Bit Selection" screen (see Section 3.2.2.3) and pressing the "▼" key accepts the present value and advance to the "Address Setting" screen (see Section 3.2.2.1).

Pressing the "←" key sets the value and shows the "Baud Rate" screen (see Section 3.2.2.2).

**NOTE: Default value is set as '9.6 kbps' for MODBUS.**

**NOTE: Default value is set as '2.4 kbps' for MBUS.**

### 3.2.2.3. Parity and Stop Bit

A monochrome LCD screen displaying the text "Pr.St.nonE1" in a pixelated font. The screen is enclosed in a dashed rectangular border.

This screen allows the user to set Parity and Number of Stop Bits .

Pressing "▲" key accepts the present value and advances to "Quit Communication Parameters" screen (see section 3.2.2.4). Similarly, pressing "▼" key accepts the present value and advances to "Baud Rate" screen (see section 3.2.2.2).

Pressing the "◀" key advances to the "Parity & Stop bit Edit" mode & keys "▲" and "▼" scrolls the value through:  
**nonE1** : no parity with one stop bit    **nonE2** : no parity with two stop bit  
**EVEn1** : even parity with one stop bit    **odd1** : odd parity with one stop bit  
for MODBUS. For MBUS only EVEn1: even parity is settable.

Pressing "◀" key sets the value and advances to "Parity Selection" screen (see Section 3.2.2.3).

**NOTE: Default value is set as 'nonE1'.**

### 3.2.2.4. Quit Communication Parameters

A monochrome LCD screen displaying the text "Quit." in a pixelated font. The screen is enclosed in a dashed rectangular border.

This screen allows user to exit from system "Communication Parameter Selection" setup.

Pressing the "▲" key advances to "Address Setting" screen (see Section 3.2.2.1). Similarly, pressing the "▼" key advances to "Parity" screen (see Section 3.2.2.3).

Pressing the "◀" key advances to "Communication Parameter Selection" screen (see Section 3.2.2).

### 3.2.3. Output Parameter Selection

This screen applies to the SO Output option selection. Pressing "←" key advances to "SO Output Selection" menu (see Section 3.2.3.1).

#### 3.2.3.1. SO1 Output Selection

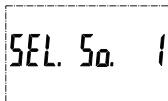

A screenshot of a digital display showing the text "SEL. SO. 1" in a monospaced font. The text is enclosed in a dashed rectangular border.

Pressing "▲" and "▼" keys scrolls through the following screens:

**SO. 1 :** To select options for SO1 Output (See section 3.2.3.1).

**SO. 2 :** To select options for SO2 Output (See section 3.2.3.2).

**quit :** To exit the Output Options menu and give the "Output Option Selection" screen (see Section 3.2.3.3).

Pressing "←" key advances to SO Output 1 Selection menu (see Section 3.2.3.1.1).

#### 3.2.3.2. SO2 Output Selection

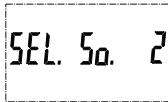

A screenshot of a digital display showing the text "SEL. SO. 2" in a monospaced font. The text is enclosed in a dashed rectangular border.

Pressing "▲" and "▼" keys scrolls through the following screens:

**SO. 1 :** To select options for SO1 Output (See section 3.2.3.1).

**SO. 2 :** To select options for SO2 Output (See section 3.2.3.2).

**quit :** To exit the Output Options menu and give the "Output Option Selection" screen (see Section 3.2.3.3).

Pressing "←" key advances to SO Output 2 Selection menu (see Section 3.2.3.1.1).

#### 3.2.3.3. Quit Pulse Output



A screenshot of a digital display showing the text "quit." in a monospaced font. The text is enclosed in a dashed rectangular border.

The screen allows user to exit the SO Output selection menu.

Pressing "▲" key advances to the "SO1 Output Selection" menu (see Section 3.2.3.1) and pressing "▼" key advances to the "SO Output 2 Selection" menu (See section 3.2.3.2).

Pressing "←" key advances to the "Output Parameter Selection" menu (see Section 3.2.3).

### 3.2.3.1.1. Output Selection for SO1 or SO2 Menu



Pressing "←" key makes the following options available for SO1 Output and SO2 Output :

0. **None:** SO Output is disabled (see Section 3.2.3.1.1.1)

1. **Pulse:** SO Output is enabled and in pulse mode (see Section 3.2.3.1.1.2)

Press "▲" and "▼" keys to navigate between the above options and press "→" key to confirm the selection.

**NOTE :** The default option is set as 'Pulse'.



#### 3.2.3.1.1.1. None Output



This screen indicates that SO 1 Output is disabled.

Pressing "▲" or "▼" key takes the user advances to "Quit Pulse Output" menu (see Section 3.2.4.1.1.6).

#### 3.2.3.1.1.2. Pulse Output



This screen indicates that SO 1 Output is disabled.

Pressing "▲" key advances to "Parameter Selection" screen (see Section 3.2.3.1.1.3) whereas pressing "▼" key advances to "Quit Pulse Output" menu (see Section 3.2.4.1.1.6).

### 3.2.3.1.1.3. Parameter Selection



This screen allows the user to assign energy for pulse output. Pressing "▲" key accepts the present setting and advance to "Pulse rate selection" (see section 3.2.3.1.1.4) and pressing "▼" key accepts the present setting and advance to "Pulse Output" selection (see section 3.2.3.1.1.2).

Pressing the "←" key advances to edit mode and "▲" and "▼" keys scrolls through the values, as per **TABLE 3**, "parameters for pulse output".



Pressing the "←" key sets the value & gives the "Parameter Selection" menu (see section 3.2.3.1.1.3).

**NOTE: Default configuration is set as '0', i.e., Total Active Energy for SO1 and '3' i.e. Total Reactive Energy for SO2.**

### 3.2.3.1.1.4. Pulse Duration



This screen applies only to the Pulse mode of SO Output. This screen allows the user to set SO Output pulse duration time in milliseconds.

Pressing "▲" key accepts the present value and advance to "Quit Pulse Output screen" ( see Section 3.2.4.1.1.6). Similarly, pressing "▼" key accepts the present value and advance to "Pulse Rate Selection" screen ( see Section 3.2.3.1.1.4).

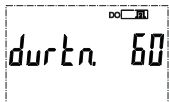

Pressing the "←" key advances to "Pulse Duration Edit" mode and "▲" and "▼" keys scroll the value through **60, 100 and 200** ms.

Pressing the "←" key selects the value and advances to "Pulse Duration" menu (see Section 3.2.3.1.1.5).

**NOTE: Default value is set to '60' ms.**

### 3.2.3.1.1.5. Pulse Rate

The screen allows user to set the following pulse rates: 0.01, 0.1, 1, 10, 100, 500 and 1000 impulse/(kWh or kVARh).



Pressing "▲" key accepts the present selection and takes to the "Pulse Duration" menu (See section 3.2.4.1.1.1.5) and pressing "▼" key accepts the present selection and takes to the "Parameter Selection" menu (see section 3.2.3.1.1.3).



Pressing the "◀" key advances to "Pulse Rate Edit" mode & keys "▲" and "▼" scrolls the value through the values 0.01, 0.1, 1, 10, 100, 500 impulse/(kWh or kVARh).

Pressing the "◀" key gives the "Pulse Rate" screen (see Section 3.2.4.1.1.1.5).

**The default setting is '1000'.**

### 3.2.3.1.1.6. Quit Pulse Output



The screen allows user to exit the Pulse Output selection menu.

Pressing "▲" key advances to the "Pulse Output" menu (see Section 3.2.3.1.1.1) and pressing "▼" key advances to the "Pulse Duration" menu (see Section 3.2.3.1.1.5).

Pressing "◀" key advances to the "SO Output Selection" menu (see Section 3.2.3.1).

## 3.2.4. Display Parameter Selection

### 3.2.4.1. Backlit

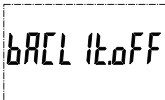

This screen allows the user to switch the backlit on or configuration off time delay.

Pressing the "▲" and "▼" keys advances to "Display Test Screen" (see Section 3.2.5.2) and "Quit Display Parameters" menu (see Section 3.2.5.3), respectively.

Pressing the "◀" key takes the user into edit mode.



In Edit Mode, pressing "▲" and "▼" keys allows the user to scroll between On/OFF/1/5/30/60(mins) and pressing "◀" key confirms the selection.

**Note:** Default value is set to '1 minute'.

### 3.2.4.2. Display Test Screen



This screen allows the user to check if there is any fault in one of the symbols or segments on the LCD display by completely turning on the display.

Pressing "▲" and "▼" key advances to Quit Screen (see Section 3.2.5.3) and Backlit Screen (see Section 3.2.5.1) respectively. Whereas pressing "←" key advances to the all ON Display.



After 5 seconds the unit automatically returns to "Display Test" (see Section 3.2.5.2) menu screen.

### 3.2.4.3. Quit Display Parameters



This screen allows user to Exit from Display Parameter Selection setup.

Pressing the "▲" key advances to "Select Backlit Para" screen. (see Section 3.2.5.1). Whereas pressing the "▼" key advances to "Display Test screen" screen. (see Section 3.2.5.2).

Pressing the "←" key advances to "Display Parameter Selection" screen (see Section 3.2.5).

## 3.2.5. Reset Parameter Selection

### 3.2.5.1. Partial Energy Reset



This screen allows the user to reset the Partial Energy Registers.

Pressing the "▲" and "▼" keys advances to "Max Demand Reset" (see Section 3.2.6.2) and "Quit Reset Parameters" menu (see Section 3.2.6.5), respectively.

Pressing the "←" key advances to "confirmation" screen and resets the parameter selected followed by "Partial Energy Reset" screen.

### 3.2.5.2. Max Demand Reset



This screen allows the user to reset the Max Demand Registers for Current and Power Parameters.

Pressing the "▲" and "▼" keys advances to "Setup Parameter Reset" (see Section 3.2.6.3) and "Partial Energy Reset" menu (see Section 3.2.6.1), respectively.

Pressing the "←" key advances to "confirmation" screen and resets the parameter selected followed by "Max Demand Reset" screen.

### 3.2.5.3. Setup Parameter Reset

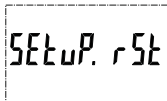

This screen allows the user to reset all the user editable Setup Parameters.

Pressing the "▲" and "▼" keys advances to Code Reset" (see Section 3.2.6.4) and "Max Demand Reset" menu (see Section 3.2.6.2), respectively.

Pressing the "←" key advances to "confirmation" screen and resets the parameter selected followed by "Setup Parameter Reset" screen.

### 3.2.5.4. Code Reset

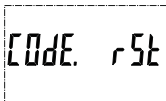

This screen allows the user to reset the Password to default value 0000.

Pressing the "▲" and "▼" keys advances to "Factory Reset Parameter" (see Section 3.2.6.5) and "Setup Parameter Reset" menu (see Section 3.2.6.3), respectively.

Pressing the "◀" key advances to "confirmation" screen and resets the parameter selected followed by "Code Reset" screen.

### 3.2.5.5. Reset All



This screen allows the user to reset the Partial Energy Registers, Max Demand and Setup Parameters to Factory default values.

Pressing the "▲" and "▼" keys advances to "Quit Reset Parameter" (see Section 3.2.6.6) and "Code Reset" menu (see Section 3.2.6.4), respectively.

Pressing the "◀" key advances to "Confirmation" screen and resets the parameter selected followed by "Reset All" screen.

### 3.2.5.6. Quit Reset Parameter

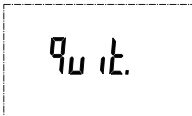

This screen allows user to Exit from Reset Parameter Selection setup.

Pressing the "▲" key advances to "Partial Energy Reset" screen. (see Section 3.2.6.1). Whereas pressing the "▼" key advances to "Factory Reset" screen. (see Section 3.2.6.5).

Pressing the "◀" key advances to "Reset Parameter Selection" screen (see Section 3.2.6).

### 3.2.6. Quit Setup



This screen will take the user out of the Setup Parameters to the Measurement Parameters window.

Pressing the "▲" and "▼" keys advances to "System Parameters" (see Section 3.2.6.1) and "Reset Parameter" menu (see Section 3.2.6), respectively.

Pressing the "◀" key will quit the Setup Parameters menu.

## 4. Tariff Input :

The meter is provided with 2 Tariff Inputs for selection of 4 active tariff for energy metering.

### 4.1. Tariff Input and Tariff Selection:

**TABLE 2 : Relationship between Tariff Input and Tariff**

Number of Tariff Input = 2; Tariff = 4

Tariff Input 1	Tariff Input 2	Tariff number
LOW	LOW	Tariff 1
HIGH	LOW	Tariff 2
LOW	HIGH	Tariff 3
HIGH	HIGH	Tariff 4

## 5. SO Output :

The Meter is provided with two opto-isolated pulse outputs that can be configured for any one of the Active and Reactive Energy (Total/ Import/ Export) parameters. Refer TABLE 3 for parameters for pulse output. The pulse width and rate of pulse out is onsite programmable .

### 5.1. Pulse Output :

Pulse Output is opto-coupler based SO which can be used to drive an external mechanical counter for energy measurement. The Pulse Output can be configured to the parameters mentioned in TABLE 3 through setup parameter screen:

**TABLE 3 : Parameters for Pulse Output**

Parameter Number	Parameter	3P4W	3P 3W	1P 2W
0	Total Active Energy	✓	✓	✓
1	Import Active Energy	✓	✓	✓
2	Export Active Energy	✓	✓	✓
3	Total Reactive Energy	✓	✓	✓
4	Import Reactive Energy	✓	✓	✓
5	Export Reactive Energy	✓	✓	✓

**Note :** If the Pulse rate is set to 500 or 1000 Impulses/kWh/kVARh and if System power (kW or kVA which ever is applicable) goes above 13 kW/kVA limit then the pulse duration is reduced to 20ms.

## 6. RS 485 (ModBus) Output :

The Instruments supports MODBUS (RS485) RTU protocol (2-wire) .

Connections should be made using twisted pair shielded cable to ensure signal integrity and minimize electromagnetic interference. All "A" and "B" terminals must be daisy-chained across devices to maintain proper communication flow. Additionally, all screens should be connected to the "Gnd" (Ground) terminal. To prevent the risk of loop currents, an Earth connection should be established at a single point within the network. Loop (Ring) Topology: Does not require termination resistors. Line (Bus) Topology: May require termination depending on the cable type and length. If termination is needed, it must be applied at both ends of the communication line. The termination resistors should match the characteristic impedance of the cable, typically 120 ohms (minimum ¼ Watt).

The RS-485 communication network supports a maximum cable length of up to 1.2 km. Including the master device, up to 32 instruments can be connected within a single RS-485 network. The permissible device address range for the meter is 1 to 247, ensuring compatibility with standard MODBUS addressing conventions. Broadcast mode (address 0) is not supported by the meter.

When a query is sent from the master device via software, a minimum wait time of 300 milliseconds must be observed before concluding that the meter has not responded. If the slave (meter) fails to respond within this time frame, the master may disregard the previous query and issue a new one

Each byte in RTU mode has following format:

	8-bit binary, hexadecimal 0-9, A-F 2 hexadecimal characters contained in each 8-bit field of the message
<b>Format of Data Bytes</b>	4 bytes (32 bits) per parameter. Floating point format ( to IEEE 754) Most significant byte first (Alternative least significant byte first)
<b>Error Checking Bytes</b>	2 byte Cyclical Redundancy Check (CRC)
<b>Byte format</b>	1 start bit, 8 data bits, least significant bit sent first 1 bit for even/odd parity 1 stop bit if parity is used; 1 or 2 bits if no parity

Communication Baud Rate is user selectable from the front panel between 4800,9600,19200,38400,57600 bps.

**Function code :**

03 (HEX)	Read Holding Registers	Read content of read /write location ( 4X )
04 (HEX)	Read input Registers	Read content of read only location ( 3X )
10 (HEX)	Presents Registers	Set the content of read / write locations ( 4X )

**Exception Cases :** An exception code will be generated when the meter receives a ModBus query with valid parity & error check but which contains some other error ( e.g. Attempt to set floating point variable to an invalid value) The response generated will be "Function Code" ORed with HEX (80H) . The exception codes are listed below

01	Illegal function	The function code is not supported by Meter
02	Illegal Data Address	Attempt to access an invalid address or an attempt to read or write part of a floating point value
03	Illegal DataValue	Attempt to set a floating point variable to an invalid value

### 6.1. Accessing 3X and 4X register for reading measured values:

Two consecutive 16 bit registers represent one parameter. Refer **TABLE 4** for the addresses of 3X and 4X registers used for parameters measured by the instrument. Each parameter is held in the 3X as well as 4X registers. Modbus Code 04 and 03 are used to access all parameters in 3X and 4X registers respectively.

#### Example :

To read parameter,

Voltage2 from 3X: Start address= 00 02      Number of registers = 02

Watt2 from 4X:      Start address= 00 0E      Number of registers = 02

#### Note : Number of registers = Number of parameters x 2

Each query for reading the data must be restricted to 40 parameters or less. Exceeding the 40 parameter limit will cause a ModBus exception code to be returned.

#### Query for 3X read:

01 (Hex)	04 (Hex)	00 (Hex)	02(Hex)	00 (Hex)	02(Hex)	30 (Hex)	0A (Hex)
Device Address	Function Code	Start Address High	Start Address Low	Number of Registers Hi	Number of Registers Lo	CRC Low	CRC High

#### 3X Response: Voltage 2 (219.254V)

01 (Hex)	04 (Hex)	04 (Hex)	43 (Hex)	5B (Hex)	41 (Hex)	21 (Hex)	6F (Hex)	9B (Hex)
Device Address	Function Code	Byte Count	Data Register1 High Byte	Data Register1 Low Byte	Data Register2 High Byte	Data Register2 Low Byte	CRC Low	CRC High

Byte Count : Total number of data bytes received.

#### Query for 4X read:

01 (Hex)	03 (Hex)	00 (Hex)	0E(Hex)	00 (Hex)	02(Hex)	E0 (Hex)	C9 (Hex)
Device Address	Function Code	Start Address High	Start Address Low	Number of Registers Hi	Number of Registers Lo	CRC Low	CRC High

#### 4X Response: Watt2 (2000 W)

01 (Hex)	03 (Hex)	04 (Hex)	44 (Hex)	FA (Hex)	00 (Hex)	00 (Hex)	CE (Hex)	F2 (Hex)
Device Address	Function Code	Byte Count	Data Register1 High Byte	Data Register1 Low Byte	Data Register2 High Byte	Data Register2 Low Byte	CRC Low	CRC High

Byte count : No. of Bytes Demanded by user in query.

Start Address High : Most significant 8 bits of starting address of the parameter requested.

Start Address low : Least significant 8 bits of starting address of the parameter requested.

Number of register Hi : Most significant 8 bits of Number of registers requested.

Number of register Lo : Least significant 8 bits of Number of registers requested.

Data register 1 High Byte : Most significant 8 bits of Data register 1 of the parameter requested.

Data register 1 Low Byte : Least significant 8 bits of Data register 1 of the parameter requested.

Data register 2 High Byte : Most significant 8 bits of Data register 2 of the parameter requested.

Data register 2 Low Byte : Least significant 8 bits of Data register 2 of the parameter requested.

**(Note : Two consecutive 16 bit register represent one parameter.)**

**TABLE 4 : 3X and 4X register addresses for measured parameters**

**TABLE 4.1 : 3X and 4X register addresses for Regular Parameters**

Address (3X)	Address (4X)	Parameter Number	Parameter	Unit	Start Address Hex 3X(Byte)		Start Address Hex 4X (Byte)	
					High	Low	High	Low
30001	40001	1	Voltage L1 (Voltage L12 for 3P3W)	Volts	00	01	00	01
30003	40003	2	Voltage L2 (Voltage L23 for 3P3W)	Volts	00	03	00	03
30005	40005	3	Voltage L3 (Voltage L31 for 3P3W)	Volts	00	05	00	05
30007	40007	4	Current L1	Amp	00	07	00	07
30009	40009	5	Current L2	Amp	00	09	00	09
30011	40011	6	Current L3	Amp	00	0B	00	0B
30013	40013	7	Watt L1	Watt	00	0D	00	0D
30015	40015	8	Watt L2	Watt	00	0F	00	0F
30017	40017	9	Watt L3	Watt	00	11	00	11
30019	40019	10	VA L1	VA	00	13	00	13
30021	40021	11	VA L2	VA	00	15	00	15
30023	40023	12	VA L3	VA	00	17	00	17
30025	40025	13	VAR L1	VAr	00	19	00	19
30027	40027	14	VAR L2	VAr	00	1B	00	1B

TABLE 4.1 Continued...

30029	40029	15	VAR L3	VAr	00	1D	00	1D
30031	40031	16	Power Factor L1	-	00	1F	00	1F
30033	40033	17	Power Factor L2	-	00	21	00	21
30035	40035	18	Power Factor L3	-	00	23	00	23
30037	40037	19	Phase Angle L1	Deg	00	25	00	25
30039	40039	20	Phase Angle L2	Deg	00	27	00	27
30041	40041	21	Phase Angle L3	Deg	00	29	00	29
30043	40043	22	Voltage Avg	Volts	00	2B	00	2B
30045	40045	23	Voltage Sum	Volts	00	2D	00	2D
30047	40047	24	Current Avg	Amp	00	2F	00	2F
30049	40049	25	Current Sum	Amp	00	31	00	31
30051	40051	26	Watt Avg	Watt	00	33	00	33
30053	40053	27	Watt Sum	Watt	00	35	00	35
30055	40055	28	VA Avg	VA	00	37	00	37
30057	40057	29	VA Sum	VA	00	39	00	39
30059	40059	30	VAR Avg	VAr	00	3B	00	3B
30061	40061	31	VAR Sum	VAr	00	3D	00	3D
30063	40063	32	PF Avg	-	00	3F	00	3F
30065	40065	33	PF Sum	-	00	41	00	41
30067	40067	34	Phase Angle Avg	Deg	00	43	00	43
30069	40069	35	Phase Angle Sum	Deg	00	45	00	45
30071	40071	36	Frequency	Hz	00	47	00	47
30073	40073	37	Active Import Energy	kWh	00	49	00	49
30075	40075	38	Active Export Energy	kWh	00	4B	00	4B
30077	40077	39	Reactive Import Energy	kVArh	00	4D	00	4D
30079	40079	40	Reactive Export Energy	kVArh	00	4F	00	4F
30081	40081	41	-----	-	00	51	00	51
30083	40083	42	-----	-	00	53	00	53
30085	40085	43	W Imp demand	Watt	00	55	00	55
30087	40087	44	Max W Imp Demand	Watt	00	57	00	57
30089	40089	45	W Exp Demand	Watt	00	59	00	59
30091	40091	46	Max W Exp Demand	Watt	00	5B	00	5B
30093	40093	47	VAr Imp. demand	VAr	00	5D	00	5D
30095	40095	48	Max VAr Imp. Demand	VAr	00	5F	00	5F
30097	40097	49	VAr Exp. Demand	VAr	00	61	00	61
30099	40099	50	Max VAr Exp. demand	VAr	00	63	00	63
30101	40101	51	VA Demand	VA	00	65	00	65
30103	40103	52	VA Max Demand	VA	00	67	00	67
30105	40105	53	Current Demand	Amp	00	69	00	69

TABLE 4.1 Continued...

30103	40103	52	VA Max Demand	VA	00	67	00	67
30105	40105	53	Current Demand	Amp	00	69	00	69
30107	40107	54	Max Current Demand	Amp	00	6B	00	6B
30109	40109	55	-	-	00	6D	00	6D
30111	40111	56	Active Import Energy	kWh	00	6F	00	6F
30113	40113	57	-	-	00	71	00	71
30115	40115	58	Active Export Energy	kWh	00	73	00	73
30117	40117	59	-	-	00	75	00	75
30119	40119	60	Reactive Import Energy	kVArh	00	77	00	77
30121	40121	61	-	-	00	79	00	79
30123	40123	62	Reactive Export Energy	kVArh	00	7B	00	7B
30125	40125	63	-	-	00	7D	00	7D
30127	40127	64	Apparent Energy	kVAh	00	7F	00	7F
30201	40201	101	V12	Volts	00	C9	00	C9
30203	40203	102	V23	Volts	00	CB	00	CB
30205	40205	103	V31	Volts	00	CD	00	CD
30207	40207	104	VTHD-L1 (VTHD-L12 for 3P3W)	%THD	00	CF	00	CF
30209	40209	105	VTHD-L2 (VTHD-L23 for 3P3W)	%THD	00	D1	00	D1
30211	40211	106	VTHD-L3 (VTHD-L31 for 3P3W)	%THD	00	D3	00	D3
30213	40213	107	ITHD-L1	%THD	00	D5	00	D5
30215	40215	108	ITHD-L2	%THD	00	D7	00	D7
30217	40217	109	ITHD-L3	%THD	00	D9	00	D9
30219	40219	110	System V-THD	%THD	00	DB	00	DB
30221	40221	111	System I-THD	%THD	00	DD	00	DD
30225	40225	113	-	-	00	E1	00	E1
30227	40227	114	Run hour	Hr	00	E3	00	E3

**TABLE 4.2 : 3X and 4X register addresses for Demand Values**

Address (3X)	Address (4X)	Parameter Number	Parameter	Unit	Start Address Hex 3X (Byte)		Start Address Hex 4X (Byte)	
					High	Low	High	Low
30501	40501	1	System Current Demand	Amp	01	F5	01	F5
30503	40503	2	L1 Current Demand	Amp	01	F7	01	F7
30505	40505	3	L2 Current Demand	Amp	01	F9	01	F9
30507	40507	4	L3 Current Demand	Amp	01	FB	01	FB
30509	40509	5	System Active Power Demand	Watt	01	FD	01	FD
30511	40511	6	System Import Active Power Demand	Watt	01	FF	01	FF
30513	40513	7	System Export Active Power Demand	Watt	02	01	02	01
30515	40515	8	System Reactive Power Demand	VAr	02	03	02	03
30517	40517	9	System Import Reactive Power Demand	VAr	02	05	02	05
30519	40519	10	System Export Reactive Power Demand	VAr	02	07	02	07
30521	40521	11	System Apparent Power Demand	VA	02	09	02	09
30523	40523	12	-	-	02	0B	02	0B
30525	40525	13	-	-	02	0D	02	0D
30527	40527	14	System Current Max Demand	Amp	02	0F	02	0F

**TABLE 4.3 : 3X and 4X register addresses for Energy**

Addr. (3X)	Addr. (4X)	Parameters	Units	Start Addr Hex 3X (Byte)		Start Addr Hex 4X (Byte)	
				High	Low	High	Low
31803	41803	Import Active Energy	kWh	07	0B	07	0B
31807	41807	Export Active Energy	kWh	07	0F	07	0F
31811	41811	Import Reactive Energy	kVArh	07	13	07	13
31815	41815	Export Reactive Energy	kVArh	07	17	07	17
31827	41827	Total Active Energy	kWh	07	23	07	23
31831	41831	Total Reactive Energy	kVArh	07	27	07	27
31835	41835	Total Apparent Energy	kVAh	07	2B	07	2B
31839	41839	T1 Import Active Energy	kWh	07	2F	07	2F
31843	41843	T1 Export Active Energy	kWh	07	33	07	33
31847	41847	T1 Import Reactive Energy	kVArh	07	37	07	37
31851	41851	T1 Export Reactive Energy	kVArh	07	3B	07	3B
31863	41863	T1 Total Active Energy	kWh	07	47	07	47
31867	41867	T1 Total Reactive Energy	kVArh	07	4B	07	4B
31871	41871	T1 Total Apparent Energy	kVAh	07	4F	07	4F
31875	41875	T2 Import Active Energy	kWh	07	53	07	53
31879	41879	T2 Export Active Energy	kWh	07	57	07	57
31883	41883	T2 Import Reactive Energy	kVArh	07	5B	07	5B
31887	41887	T2 Export Reactive Energy	kVArh	07	5F	07	5F
31899	41899	T2 Total Active Energy	kWh	07	6B	07	6B
31903	41903	T2 Total Reactive Energy	kVArh	07	6F	07	6F
31907	41907	T2 Total Apparent Energy	kVAh	07	73	07	73
31911	41911	T3 Import Active Energy	kWh	07	77	07	77
31915	41915	T3 Export Active Energy	kWh	07	7B	07	7B
31919	41919	T3 Import Reactive Energy	kVArh	07	7F	07	7F
31923	41923	T3 Export Reactive Energy	kVArh	07	83	07	83
31935	41935	T3 Total Active Energy	kWh	07	8F	07	8F
31939	41939	T3 Total Reactive Energy	kVArh	07	93	07	93
31943	41943	T3 Total Apparent Energy	kVAh	07	97	07	97
31947	41947	T4 Import Active Energy	kWh	07	9B	07	9B
31951	41951	T4 Export Active Energy	kWh	07	9F	07	9F
31955	41955	T4 Import Reactive Energy	kVArh	07	A3	07	A3

TABLE 4.3 Continued...

Addr. (3X)	Addr. (4X)	Parameters	Units	Start Addr Hex 3X (Byte)		Start Addr Hex 4X (Byte)	
				High	Low	High	Low
31959	41959	T4 Export Reactive Energy	kVArh	07	A7	07	A7
31971	41971	T4 Total Active Energy	kWh	07	B3	07	B3
31975	41975	T4 Total Reactive Energy	kVArh	07	B7	07	B7
31979	41979	T4 Total Apparent Energy	kVAh	07	BB	07	BB
31983	41983	Phase L1 Import Active Energy	kWh	07	BF	07	BF
31987	41987	Phase L1 Export Active Energy	kWh	07	C3	07	C3
31991	41991	Phase L1 Import Reactive Energy	kVArh	07	C7	07	C7
31995	41995	Phase L1 Export Reactive Energy	kVArh	07	CB	07	CB
32007	42007	Phase L1 Total Active Energy	kWh	07	D7	07	D7
32011	42011	Phase L1 Total Reactive Energy	kVArh	07	DB	07	DB
32015	42015	Phase L1 Total Apparent Energy	kVAh	07	DF	07	DF
32019	42019	Phase L2 Import Active Energy	kWh	07	E3	07	E3
32023	42023	Phase L2 Export Active Energy	kWh	07	E7	07	E7
32027	42027	Phase L2 Import Reactive Energy	kVAh	07	EB	07	EB
32031	42031	Phase L2 Export Reactive Energy	kWh	07	EF	07	EF
32043	42043	Phase L2 Total Active Energy	kWh	07	FB	07	FB
32047	42047	Phase L2 Total Reactive Energy	kVArh	07	FF	07	FF
32051	42051	Phase L2 Total Apparent Energy	kVAh	08	03	08	03
32055	42055	Phase L3 Import Active Energy	kWh	08	07	08	07
32059	42059	Phase L3 Export Active Energy	kWh	08	0B	08	0B
32063	42063	Phase L3 Import Reactive Energy	kVArh	08	0F	08	0F
32067	42067	Phase L3 Export Reactive Energy	kVArh	08	13	08	13
32079	42079	Phase L3 Total Active Energy	kWh	08	1F	08	1F
32083	42083	Phase L3 Total Reactive Energy	kVArh	08	23	08	23
32087	42087	Phase L3 Total Apparent Energy	kVAh	08	27	08	27
32091	42091	Partial Import Active Energy	kWh	08	2B	08	2B
32095	42095	Partial Export Active Energy	kWh	08	2F	08	2F
32099	42099	Partial Import Reactive Energy	kVArh	08	33	08	33
32103	42103	Partial Export Reactive Energy	kVArh	08	37	08	37
32115	42115	Partial Total Active Energy	kWh	08	43	08	43
32119	42119	Partial Total Reactive Energy	kVArh	08	47	08	47

TABLE 4.3 Continued...

Addr. (3X)	Addr. (4X)	Parameters	Units	Start Addr Hex 3X (Byte)		Start Addr Hex 4X (Byte)	
				High	Low	High	Low
32123	42123	Partial Total Apparent Energy	kVAh	08	4B	08	4B
32127	42127	T1 Partial Import Active Energy	kWh	08	4F	08	4F
32131	42131	T1 Partial Export Active Energy	kWh	08	53	08	53
32135	42135	T1 Partial Import Reactive Energy	kVArh	08	57	08	57
32139	42139	T1 Partial Export Reactive Energy	kVArh	08	5B	08	5B
32151	42151	Not to use	-	08	67	08	67
32155	42155	Not to use	-	08	6B	08	6B
32159	42159	Not to use	-	08	6F	08	6F
32163	42163	T2 Partial Import Active Energy	kWh	08	73	08	73
32167	42167	T2 Partial Export Active Energy	kWh	08	77	08	77
32171	42171	T2 Partial Import Reactive Energy	kVArh	08	7B	08	7B
32175	42175	T2 Partial Export Reactive Energy	kVArh	08	7F	08	7F
32187	42187	Not to use	-	08	8B	08	8B
32191	42191	Not to use	-	08	8F	08	8F
32195	42195	Not to use	-	08	93	08	93
32199	42199	T3 Partial Import Active Energy	kWh	08	97	08	97
32203	42203	T3 Partial Export Active Energy	kWh	08	9B	08	9B
32207	42207	T3 Partial Import Reactive Energy	kVArh	08	9F	08	9F
32211	42211	T3 Partial Export Reactive Energy	kVArh	08	A3	08	A3
32223	42223	Not to use	-	08	AF	08	AF
32227	42227	Not to use	-	08	B3	08	B3
32231	42231	Not to use	-	08	B7	08	B7
32235	42235	T4 Partial Import Active Energy	kWh	08	BB	08	BB
32239	42239	T4 Partial Export Active Energy	kWh	08	BF	08	BF
32243	42243	T4 Partial Import Reactive Energy	kVArh	08	C3	08	C3
32247	42247	T4 Partial Export Reactive Energy	kVArh	08	C7	08	C7
32259	42259	Not to use	-	08	D3	08	D3
32263	42263	Not to use	-	08	D7	08	D7
32267	42267	Not to use	-	08	DB	08	DB

**Note:** 1. For 3P3W and 1P2W System, phase-wise parameters are not available.

**TABLE 4.4 : 3X and 4X register addresses for Long Energy**

Addr. (3X)	Addr. (4X)	Parameters	Units	Start Addr Hex 3X (Byte)		Start Addr Hex 4X (Byte)	
				High	Low	High	Low
32803	42803	Import Active Energy	kWh	0A	F3	0A	F3
32807	42807	Export Active Energy	kWh	0A	F7	0A	F7
32811	42811	Import Reactive Energy	kVArh	0A	FB	0A	FB
32815	42815	Export Reactive Energy	kVArh	0A	FF	0A	FF
32827	42827	Total Active Energy	kWh	0B	0B	0B	0B
32831	42831	Total Reactive Energy	kVArh	0B	0F	0B	0F
32835	42835	Total Apparent Energy	kVAh	0B	13	0B	13
32839	42839	T1 Import Active Energy	kWh	0B	17	0B	17
32843	42843	T1 Export Active Energy	kWh	0B	1B	0B	1B
32847	42847	T1 Import Reactive Energy	kVArh	0B	1F	0B	1F
32851	42851	T1 Export Reactive Energy	kVArh	0B	23	0B	23
32863	42863	T1 Total Active Energy	kWh	0B	2F	0B	2F
32867	42867	T1 Total Reactive Energy	kVArh	0B	33	0B	33
32871	42871	T1 Total Apparent Energy	kVAh	0B	37	0B	37
32875	42875	T2 Import Active Energy	kWh	0B	3B	0B	3B
32879	42879	T2 Export Active Energy	kWh	0B	3F	0B	3F
32883	42883	T2 Import Reactive Energy	kVArh	0B	43	0B	43
32887	42887	T2 Export Reactive Energy	kVArh	0B	47	0B	47
32899	42899	T2 Total Active Energy	kWh	0B	53	0B	53
32903	42903	T2 Total Reactive Energy	kVArh	0B	57	0B	57
32907	42907	T2 Total Apparent Energy	kVAh	0B	5B	0B	5B
32911	42911	T3 Import Active Energy	kWh	0B	5F	0B	5F
32915	42915	T3 Export Active Energy	kWh	0B	63	0B	63
32919	42919	T3 Import Reactive Energy	kVArh	0B	67	0B	67
32923	42923	T3 Export Reactive Energy	kVArh	0B	6B	0B	6B
32935	42935	T3 Total Active Energy	kWh	0B	77	0B	77
32939	42939	T3 Total Reactive Energy	kVArh	0B	7B	0B	7B
32943	42943	T3 Total Apparent Energy	kVAh	0B	7F	0B	7F
32947	42947	T4 Import Active Energy	kWh	0B	83	0B	83
32951	42951	T4 Export Active Energy	kWh	0B	87	0B	87
32955	42955	T4 Import Reactive Energy	kVArh	0B	8B	0B	8B

TABLE 4.4 Continued...

Addr. (3X)	Addr. (4X)	Parameters	Units	Start Addr Hex 3X (Byte)		Start Addr Hex 4X (Byte)	
				High	Low	High	Low
32959	42959	T4 Export Reactive Energy	kVArh	0B	8F	0B	8F
32971	42971	T4 Total Active Energy	kWh	0B	9B	0B	9B
32975	42975	T4 Total Reactive Energy	kVArh	0B	9F	0B	9F
32979	42979	T4 Total Apparent Energy	kVAh	0B	A3	0B	A3
32983	42983	Phase L1 Import Active Energy	kWh	0B	A7	0B	A7
32987	42987	Phase L1 Export Active Energy	kWh	0B	AB	0B	AB
32991	42991	Phase L1 Import Reactive Energy	kVArh	0B	AF	0B	AF
32995	42995	Phase L1 Export Reactive Energy	kVArh	0B	B3	0B	B3
33007	43007	Phase L1 Total Active Energy	kWh	0B	BF	0B	BF
33011	43011	Phase L1 Total Reactive Energy	kVArh	0B	C3	0B	C3
33015	43015	Phase L1 Total Apparent Energy	kVAh	0B	C7	0B	C7
33019	43019	Phase L2 Import Active Energy	kWh	0B	CB	0B	CB
33023	43023	Phase L2 Export Active Energy	kWh	0B	CF	0B	CF
33027	43027	Phase L2 Import Reactive Energy	kVArh	0B	D3	0B	D3
33031	43031	Phase L2 Export Reactive Energy	kVArh	0B	D7	0B	D7
33043	43043	Phase L2 Total Active Energy	kWh	0B	E3	0B	E3
33047	43047	Phase L2 Total Reactive Energy	kVArh	0B	E7	0B	E7
33051	43051	Phase L2 Total Apparent Energy	kVAh	0B	EB	0B	EB
33055	43055	Phase L3 Import Active Energy	kWh	0B	EF	0B	EF
33059	43059	Phase L3 Export Active Energy	kWh	0B	F3	0B	F3
33063	43063	Phase L3 Import Reactive Energy	kVArh	0B	F7	0B	F7
33067	43067	Phase L3 Export Reactive Energy	kVArh	0B	FB	0B	FB
33079	43079	Phase L3 Total Active Energy	kWh	0C	07	0C	07
33083	43083	Phase L3 Total Reactive Energy	kVArh	0C	0B	0C	0B
33087	43087	Phase L3 Total Apparent Energy	kVAh	0C	0F	0C	0F
33091	43091	Partial Import Active Energy	kWh	0C	13	0C	13
33095	43095	Partial Export Active Energy	kWh	0C	17	0C	17
33099	43099	Partial Import Reactive Energy	kVArh	0C	1B	0C	1B
33103	43103	Partial Export Reactive Energy	kVArh	0C	1F	0C	1F
33115	43115	Partial Total Active Energy	kWh	0C	2B	0C	2B
33119	43119	Partial Total Reactive Energy	kVArh	0C	2F	0C	2F

TABLE 4.4 Continued...

Addr. (3X)	Addr. (4X)	Parameters	Units	Start Addr Hex 3X (Byte)		Start Addr Hex 4X (Byte)	
				High	Low	High	Low
33123	43123	Partial Total Apparent Energy	kVArh	0C	33	0C	33
33127	43127	T1 Partial Import Active Energy	kWh	0C	37	0C	37
33131	43131	T1 Partial Export Active Energy	kWh	0C	3B	0C	3B
33135	43135	T1 Partial Import Reactive Energy	kVArh	0C	3F	0C	3F
33139	43139	T1 Partial Export Reactive Energy	kVArh	0C	43	0C	43
33151	43151	Not to use	-	0C	4F	0C	4F
33155	43155	Not to use	-	0C	53	0C	53
33159	43159	Not to use	-	0C	57	0C	57
33163	43163	T2 Partial Import Active Energy	kWh	0C	5B	0C	5B
33167	43167	T2 Partial Export Active Energy	kWh	0C	5F	0C	5F
33171	43171	T2 Partial Import Reactive Energy	kVArh	0C	63	0C	63
33175	43175	T2 Partial Export Reactive Energy	kVArh	0C	67	0C	67
33187	43187	Not to use	-	0C	73	0C	73
33191	43191	Not to use	-	0C	77	0C	77
33195	43195	Not to use	-	0C	7B	0C	7B
33199	43199	T3 Partial Import Active Energy	kWh	0C	7F	0C	7F
33203	43203	T3 Partial Export Active Energy	kVArh	0C	83	0C	83
33207	43207	T3 Partial Import Reactive Energy	kVArh	0C	87	0C	87
33211	43211	T3 Partial Export Reactive Energy	kVArh	0C	8B	0C	8B
33223	43223	Not to use	-	0C	97	0C	97
33227	43227	Not to use	-	0C	9B	0C	9B
33231	43231	Not to use	-	0C	9F	0C	9F
33235	43235	T4 Partial Import Active Energy	kWh	0C	A3	0C	A3
33239	43239	T4 Partial Export Active Energy	kWh	0C	A7	0C	A7
33243	43243	T4 Partial Import Reactive Energy	kVArh	0C	AB	0C	AB
33247	43247	T4 Partial Export Reactive Energy	kVArh	0C	AF	0C	AF
33259	43259	Not to Use	-	0C	BB	0C	BB
33263	43263	Not to Use	-	0C	BF	0C	BF
33267	43267	Not to Use	-	0C	C3	0C	C3

**Note:** 1. For 3P3W and 1P2W System, phase-wise parameters are not available.

## 6.2. Accessing 4X register for Reading & Writing Settings:

Each setting is held in the 4X registers. ModBus code 01 is used to read the system type. Refer **TABLE 4** for 4X Register addresses.

### Example: Reading System type

System type: Start address = 1770 (Hex)

Number of registers = 02

**Note: Number of registers = Number of Parameters x 2**

### Query :

Device Address	01 (Hex)
Function Code	03 (Hex)
Start Address High	17 (Hex)
Start Address Low	70 (Hex)
Number of Registers High	00 (Hex)
Number of Registers Low	02 (Hex)
CRC Low	C0 (Hex)
CRC High	64 (Hex)

**Start Address High** : Most significant 8 bits of starting address of the parameter requested.

**Start Address Low** : Least significant 8 bits of starting address of the parameter requested.

**Number of register High** : Most significant 8 bits of Number of registers requested.

**Number of register Low** : Least significant 8 bits of Number of registers requested.

**(Note : Two consecutive 16 bit register represent one parameter.)**

### Response: System Type (3phase 4 wire = 3)

Device Address	01 (Hex)
Function Code	03 (Hex)
Byte Count	04 (Hex)
Data Register- 1 High Byte	40 (Hex)
Data Register- 1 Low Byte	40 (Hex)
Data Register- 2 High Byte	00 (Hex)
Data Register- 2 Low Byte	00 (Hex)
CRC Low	EE (Hex)
CRC High	27 (Hex)

**Byte Count** : Total number of data bytes received.

**Data register 1 High Byte** : Most significant 8 bits of Data register 1 of the parameter requested.

**Data register 1 Low Byte** : Least significant 8 bits of Data register 1 of the parameter requested.

**Data register 2 High Byte** : Most significant 8 bits of Data register 2 of the parameter requested.

**Data register 2 Low Byte** : Least significant 8 bits of Data register 2 of the parameter requested.

**(Note : Two consecutive 16 bit register represent one parameter.)**

### Example : Writing System type

System type : Start address = 1772 (Hex)

Number of registers = 02

**Note: Number of registers = Number of Parameters x 2**

**Query:( Change System type to 3phase 3wire = 2 )**

Device Address	01 (Hex)
Function Code	10 (Hex)
Starting Address High	17 (Hex)
Starting Address Low	72 (Hex)
Number of Registers High	00 (Hex)
Number of Registers Low	02 (Hex)
Byte Count	04 (Hex)
Data Register- 1 High Byte	40 (Hex)
Data Register- 1 Low Byte	00 (Hex)
Data Register- 2 High Byte	00 (Hex)
Data Register- 2 Low Byte	00 (Hex)
CRC Low	66 (Hex)
CRC High	10 (Hex)

**Byte Count** : Total number of data bytes received.

**Data register 1 High Byte** : Most significant 8 bits of Data register 1 of the parameter requested.

**Data register 1 Low Byte** : Least significant 8 bits of Data register 1 of the parameter requested.

**Data register 2 High Byte** : Most significant 8 bits of Data register 2 of the parameter requested.

**Data register 2 Low Byte** : Least significant 8 bits of Data register 2 of the parameter requested.

**(Note : Two consecutive 16 bit register represent one parameter)**

### Response:

Device Address	01 (Hex)
Function Code	10 (Hex)
Start Address High	17 (Hex)
Start Address Low	72 (Hex)
Number of Registers High	00 (Hex)
Number of Registers Low	02 (Hex)
CRC Low	61 (Hex)
CRC High	CA (Hex)

**Start Address High** : Most significant 8 bits of starting address of the parameter requested.

**Start Address Low** : Least significant 8 bits of starting address of the parameter requested.

**Number of register High** : Most significant 8 bits of Number of registers requested.

**Number of register Low** : Least significant 8 bits of Number of registers requested.

**(Note : Two consecutive 16 bit register represent one parameter)**

**TABLE 6 : 4X register addresses**

Address Register	Parameter Number	Parameter	Modbus Start Address		Default Value
			High Byte	Low Byte	
46001	1	Type	17	70	3
46003	2	Demand Time Integration	17	72	5
46005	3	Auto Scroll	17	74	0
46007	4	Address	17	76	1
46009	5	Baud Rate (Read Only)	17	78	9600
46011	6	Parity (Read Only)	17	7A	0
46013	7	RS485 Setup Code	17	7C	4
46015	8	Register Word Order	17	7E	0
46017	9	Pulse Output 1 Enable	17	80	1
46019	10	Pulse Output 1 Parameter	17	82	0
46021	11	Pulse Output 1 Pulse Rate	17	84	1000
46023	12	Pulse Output 1 Pulse Duration	17	86	60
46025	13	Pulse Output 2 Enable	17	88	1
46027	14	Pulse Output 2 Parameter	17	8A	3
46029	15	Pulse Output 2 Pulse Rate	17	8C	1000
46031	16	Pulse Output 2 Pulse Duration	17	8E	60
46033	17	—	17	90	0
46035	18	Active Tariff (Read Only)	17	92	-
46037	19	No of Tariff (Read Only)	17	94	4
46039	20	Backlit	17	96	1
46041	21	Test Display	17	98	0
46043	22	Partial Energy Reset	17	9A	0
46045	23	Maximum Demand Reset	17	9C	0
46047	24	Setup Parameter Reset	17	9E	0
46049	25	Reset All	17	A0	0
46051	26	Password	17	A2	0
46053	27	Power Fail Count (Read Only)	17	A4	-
46055	28	Serial Number (Read Only)	17	A6	-
46057	29	Date of Manufacturing (Read Only)	17	A8	-
46059	30	Software Version (Read Only)	17	AA	-

## Explanation for 4X register :

**NOTE:** Writing any invalid values (non-applicable values) to any of the following locations will result in modbus error.

Address Register	Parameter	Description
46001	Type	This address is used to set the System type. Write one of the following value to this address. 1 : 1 Phase 2 Wire 2 : 3 Phase 3 Wire 3 : 3 Phase 4 Wire.
46003	Demand Time Integration	Demand period represents demand time in minutes. The applicable values are 1, 5, 10, 15, 30, 60 minutes.
46005	Auto Scroll	This address is used to activate or disable the auto scrolling. Write 0: OFF 1: ON
46007	Address	This register address is used to set Device address between 1 to 247 .
46009	Baud Rate	This register indicates the baud rates and which is read only parameter.
46011	Parity and Stop Bits	This register indicates the Parity which is used for read only parameter. 0: None1 1: None2 2: Even1 3: Odd1
46013	RS485 Setup Code	This register allows user to set the desired Baud rate for RS485. It can be referred from table 7.
46015	Register Word Order	Word Order controls the order in which Multifunction Meter receives or sends floating - point numbers:- normal or reversed register order. In normal mode, the two registers that make up a floating point numbers are sent most significant bytes first. In reversed register mode, the two registers that make up a floating point numbers are sent least significant bytes first. To set the mode, write the value '2141.0' into this register-the instrument will detect the order used to send this value & set that order for all ModBus transaction involving floating point numbers.
46017	Pulse Ouput 1 Enable	This address is used to enable the Pulse Output 1 of the meter 0 - None 1 - Pulse
46019	Pulse Ouput 1 Parameter	This address allows user to select the Parameter for Pulse Output 1. It can be referred from Table 3.
46021	Pulse Ouput 1 Pulse Rate	This address allows user to select the desired Pulse Rate of the Pulse Output 1. This applicable values are - 0.01, 0.1, 1, 10, 100, 500, 1000 imp/KWh.
46023	Pulse Ouput 1 Pulse Duration	This address allows user to set the Pulse Duration of the Pulse Output 1. This applicable values are - 60ms, 100ms or 200ms.
46025	Pulse Ouput 2 Enable	This address is used to enable the Pulse Output 2 of the meter 0 - None 1 - Pulse
46027	Pulse Ouput 2 Parameter	This address allows user to select the Parameter for Pulse Output 2. It can be referred from Table 3.

46031	Pulse Output 2 Pulse Duration	This address allows the user to set the Pulse Duration of Pulse Output 2 to 60ms, 100ms or 200ms.
46033	Not to use	-
46035	Active Tariff	This address indicates the active tariff (Read Only). 1: Tariff 1 2: Tariff 2 3: Tariff 3 4: Tariff 4
46037	Not to use	-
46039	Backlit	This address is used to set the backlit on-time in minutes. Valid values are: 1, 5, 30, 60 minutes. Additionally following values are also applicable: 999: Backlit On 0: Backlit Off
46041	Test Display	This address is used to check for any faults in the LCD display by completely turning it on. Write 1 to this address for the function.
46043	Partial Energy Reset	This address allows the user to reset all the Partial Energy Counters. Write 1 to this address for the function.
46045	Maximum Demand Reset	This address allows the user to reset all the Maximum Demand Counters of Current and Power. Write 1 to this address for the function.
46047	Setup Parameter Reset	This address allows the user to reset all the Setup parameters. Write 1 to this address for the function.
46049	Reset all	This address allows the user to reset all the Parameters. Write 1 to this address for the function.
46051	Password	This address is used to unlock the Modbus for setup parameter update and also for additional functions as below: 1) If password lock is present & if this location is read it will return zero, no editing of setup parameter via Modbus will be possible. 2) If password lock is present & to disable this lock first send valid password to this location. Upon successful unlocking, the address will return 1. Setup parameter editing is now possible. 3) To set new password, the meter must be unlocked, then entering valid value will update the new password. Valid Range of Password can be set is 0000 - 9999. 4) If for in any of the above case invalid password is send then meter will return exceptional error.

46053	Power Fail Count	This register indicates the no of times the meter has suffered loss of power.
46055	Serial Number	This address is read only and displays the Serial No. of the meter.
46057	Date of Manufacturing	This address allows user to check when the Hardware is manufactured.
46059	Software Version	This address is read only and displays the firmware version of the meter.
46061	-	-
46063	-	-

**TABLE 7 : RS485 Setup Code :**

<b>Baud Rate</b>	<b>Parity</b>	<b>Stop Bit</b>	<b>Decimal Value</b>
4800	NONE	1	0
4800	NONE	2	1
4800	EVEN	1	2
4800	ODD	1	3
9600	NONE	1	4
9600	NONE	2	5
9600	EVEN	1	6
9600	ODD	1	7
19200	NONE	1	8
19200	NONE	2	9
19200	EVEN	1	10
19200	ODD	1	11
38400	NONE	1	12
38400	NONE	2	13
38400	EVEN	1	14
38400	ODD	1	15
57600	NONE	1	16
57600	NONE	2	17
57600	EVEN	1	18
57600	ODD	1	19

## 6.4. User Assignable Modbus Registers:

The Instrument contains 20 user assignable registers in the address range of 0x1450 (35201) to 0x1476 (35239) for 3X registers (see **TABLE 8**) and address range of 0x1450 (45201) to 0x1476 (45239) for 4X registers (see **TABLE 8**).

Any of the parameter addresses (3X register addresses and 4X register addresses of **TABLE 4**) accessible in the instrument can be mapped to these 20 user assignable registers.

Parameters (3X and 4X registers addresses) that reside in different locations may be accessed by the single request by re-mapping them to adjacent address in the user assignable registers area.

The actual address of the parameters (3X and 4X registers addresses) which are to be accessed via address 0x1450 to 0x1476 are specified in 4X Register 0x2710 to 0x2723 (see **TABLE 9**).

**TABLE 8 : User Assignable 3X Data Registers**

Address (3X)	Address (4X)	Assignable Register	Modbus Start Address (Hex)	
			High Byte	Low Byte
35201	45201	Assignable Register 1	14	50
35203	45203	Assignable Register 2	14	52
35205	45205	Assignable Register 3	14	54
35207	45207	Assignable Register 4	14	56
35209	45209	Assignable Register 5	14	58
35211	45211	Assignable Register 6	14	5A
35213	45213	Assignable Register 7	14	5C
35215	45215	Assignable Register 8	14	5E
35217	45217	Assignable Register 9	14	60
35219	45219	Assignable Register 10	14	62
35221	45221	Assignable Register 11	14	64
35223	45223	Assignable Register 12	14	66
35225	45225	Assignable Register 13	14	68
35227	45227	Assignable Register 14	14	6A
35229	45229	Assignable Register 15	14	6C
35231	45231	Assignable Register 16	14	6E
35233	45233	Assignable Register 17	14	70
35235	45235	Assignable Register 18	14	72
35237	45237	Assignable Register 19	14	74
35239	45239	Assignable Register 20	14	76

**TABLE 9 : User Assignable mapping register ( 4X registers)**

Address (4X)	Assignable Register	Modbus Start Address (Hex)	
		High Byte	Low Byte
410001	Map Address for Assignable Register 1	27	10
410002	Map Address for Assignable Register 2	27	11
410003	Map Address for Assignable Register 3	27	12
410004	Map Address for Assignable Register 4	27	13
410005	Map Address for Assignable Register 5	27	14
410006	Map Address for Assignable Register 6	27	15
410007	Map Address for Assignable Register 7	27	16
410008	Map Address for Assignable Register 8	27	17
410009	Map Address for Assignable Register 9	27	18
410010	Map Address for Assignable Register 10	27	19
410011	Map Address for Assignable Register 11	27	1A
410012	Map Address for Assignable Register 12	27	1B
410013	Map Address for Assignable Register 13	27	1C
410014	Map Address for Assignable Register 14	27	1D
410015	Map Address for Assignable Register 15	27	1E
410016	Map Address for Assignable Register 16	27	1F
410017	Map Address for Assignable Register 17	27	20
410018	Map Address for Assignable Register 18	27	21
410019	Map Address for Assignable Register 19	27	22
410020	Map Address for Assignable Register 20	27	23

### Assigning parameter to User Assignable Registers:

To access the Voltage2 (3X address 0x0002) and Power Factor1 (3X address 0x001E) through user assignable register assign these addresses to 4x register (**TABLE 9**) 0x2710 and 0x2711 respectively.

### Assigning Query:

Device Address	01 (Hex)
Function Code	10 (Hex)
Start Address High	27 (Hex)
Start Address Low	10 (Hex)
Number of Registers High	00 (Hex)
Number of Registers Low	02 (Hex)
Byte Count	04 (Hex)
Data Register- 1 High Byte	00 (Hex)
Data Register- 1 Low Byte	02 (Hex)
Data Register- 2 High Byte	00 (Hex)
Data Register- 2 Low Byte	1E (Hex)
CRC Low	01 (Hex)
CRC High	EC (Hex)

Voltage

2 \* (3X Address 0x0002)

Power Factor

1 \* (3X Address 0x001E)

### Response:

Device Address	01 (Hex)
Function Code	10 (Hex)
Start Address High	27 (Hex)
Start Address Low	10 (Hex)
Number of Registers High	00 (Hex)
Number of Registers Low	02 (Hex)
CRC Low	4A (Hex)
CRC High	B9 (Hex)

\* Note : Upto 6 parameters can be assigned at a time but these parameters should be assigned in Multiple of two i.e. 2, 4 or 6.

### Reading Parameter data through User Assignable Registers:

In assigning query, Voltage 2 & Power Factor 1 parameters were assigned to 0x2710 & 0x2711 (**TABLE 9**) which will point to user assignable 3x registers 0x1450 and 0x1452 (**TABLE 8**). So to read Voltage2 and Power Factor1 data reading query should be as below.

#### Query:

Device Address	01 (Hex)
Function Code	04 (Hex)
Start Address High	14 (Hex)
Start Address Low	50 (Hex)
Number of Registers High	00 (Hex)
Number of Registers Low	04 (Hex)
CRC Low	F0 (Hex)
CRC High	71 (Hex)

**Start Address High** : Most significant 8 bits of starting address of Userassignable register.

**Start Address low** :Least significant 8 bits of starting address of User assignable register.

**Number of register Hi** : Most significant 8 bits of Number of registers requested.

**Number of register Lo** : Least significant 8 bits of Number of registers requested.

**\*Note: Two consecutive 16 bit register represent one parameter. Since two parameters are requested four registers are required**

#### Response: (Volt2 = 219.30 / Power Factor1 = 1.0)

Device Address	01 (Hex)
Function Code	04 (Hex)
Byte Count	08 (Hex)
Data Register- 1 High Byte	43 (Hex)
Data Register- 1 Low Byte	5B (Hex)
Data Register- 2 High Byte	4E (Hex)
Data Register- 2 Low Byte	04 (Hex)
Data Register- 3 High Byte	3F (Hex)
Data Register- 3 Low Byte	80 (Hex)
Data Register- 4 High Byte	00 (Hex)
Data Register- 4 Low Byte	00 (Hex)
CRC Low	79 (Hex)
CRC High	3F (Hex)

Voltage 2 Data

Power Factor 1 Data

## 7. MBUS

For detailed information on the M-Bus communication Protocol, please refer to the M-Bus manual.

## 8. Installation

The Instrument should be mounted in a reasonably stable ambient temperature and where the operating temperature is within the range defined by the technical specification. Vibration should be kept to a minimum and the product should not be mounted where it will be subjected to excessive direct sunlight.

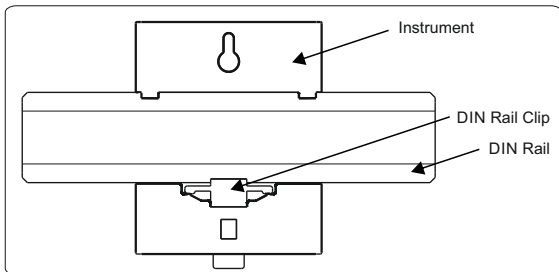

### Caution

1. In the interest of safety and functionality this product must be installed by a qualified engineer, abiding by any local regulations.
2. Voltages dangerous to human life are present at some of the terminal connections of this unit. Ensure that all supplies are de-energised before attempting any connection or disconnection.
3. These products do not have internal fuses therefore external fuses must be used to ensure safety under fault conditions.
4. The installer is responsible for selecting appropriate supply side protection overcurrent device so, it is must to ensure that the maximum current rating and characteristics of that device.

### Warning

1. Qualified personnel familiar with applicable codes and regulations must perform the installation.
2. Utilize insulated tools for device installation.
3. Install a fuse, thermal cut-off, or single-pole circuit breaker on the supply line, not on the neutral line.

## 8.1. EMC Installation Requirements

This product has been designed to meet the certification of the EU directives when installed to a good code of practice for EMC in industrial environments, e.g.

1. Screened output and low signal input leads or have provision for fitting RF suppression components, such as ferrite absorbers, line filters etc., in the event that RF fields cause problems.

**Note :** It is good practice to install sensitive electronic instruments that are performing critical functions, in EMC enclosures that protect against electrical interference which could cause a disturbance in function.

2. Avoid routing leads alongside cables and products that are, or could be, a source of interference.

3. To protect the product against permanent damage, surge transients must be limited to 2kV pk. It is good EMC practice to suppress differential surges to 2kV at the source. The unit has been designed to automatically recover in the event of a high level of transients. In extreme circumstances it may be necessary to temporarily disconnect the input to the meter for a period of greater than 5 seconds to restore correct operation.

4. ESD precautions must be taken at all times when handling this product.

## 8.2. Case Dimensions

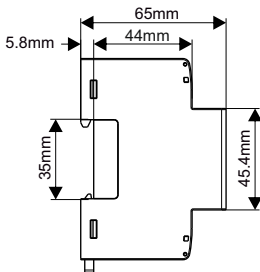
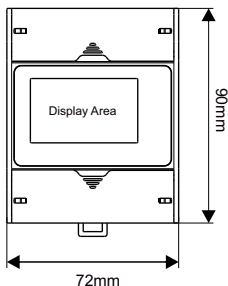

## 8.3. Name Plate

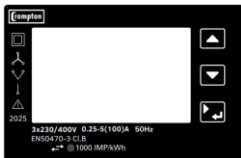



## 8.4 Wiring

Input connections are made directly to screw-type terminals with indirect wire pressure. Numbering is clearly marked at the connector location. Choice of cable should meet local regulations.

**Note:** It is recommended to use wire with insulated pin type lug for connection with meter.

Wire: It is suggested to use wire with a temperature rating of at least 83 Deg. C

**It is mandatory to use Screw Plug for covering the L1, L2, L3 and LN (IN & OUT) Terminal.**

	ISO 7000-0434B(2004-01)	CAUTION
	ISO 7000-1641	Operating Instructions

Connections	Cable Size (mm <sup>2</sup> )	Torque Nm
<b>L1, L2, L3, LN (IN &amp; OUT)</b>	6 - 25 mm <sup>2</sup> use insulated pin types lugs	2.5 - 3.0 Nm
<b>B+, A-, G, M+, M-, SO1+, SO1-, SO2+, SO2-, TA, TB</b>	1 - 2.5 mm <sup>2</sup> Stranded with pin types lugs	0.4 Nm

## 8.5 Fusing

It is recommended to choose fuse of a type and with breaking capacity appropriate to the supply and in accordance with local regulations.

## 8.6 Sealing

As per the MID standard It is mandatory to seal the meter after complete connections of the meter to avoid tampering.

In the Packing box 2 utility seal are provided.

Follow the below procedure for sealing the meter : -

- 1) After all the connections close the upper terminal cover
- 2) In order to lock the terminal cover, press at the two edge of the terminal cover.
- 3) Now, insert the seal cord through the terminal sealing hole of housing & terminal cover.
- 4) Then insert the cord into the security seal hole and rotate the seal cap 2 to 3 times to lock the cord.
- 5) After sealing the meter brake the seal cap.
- 6) Repeat these steps for the lower terminal cover.
- 7) After sealing the meter brake the seal cap.

## 9. Errors and Dignostics

The instrument continuously monitors its operation for various error and warning conditions. If an error is detected, it is immediately displayed on the screen, as such conditions are considered critical and may impair normal functionality. In these cases, the instrument may require immediate replacement or servicing. For remote diagnostics, the corresponding error registers are mapped to MODBUS registers, allowing integration with monitoring systems to assess instrument health in real time.

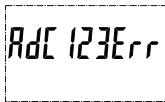

ADCs Error



CRC mismatch in the calibration coefficient

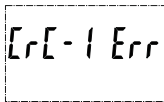

CRC-1 mismatch error

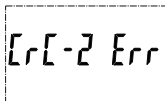

CRC-2 mismatch error



EEPROM Full notification



EEPROM Error

The error status is also available on the Modbus :

Bit 0	Error CRC-1
Bit 2	Error CRC-2
Bit 3	Calibration CRC Error
Bit 4	EEPROM Error
Bit 5	ADC Communication Error
Bit 6	EEPROM Full

## 10. Connection Diagrams

### 10.1. Connection of the meter as per model type

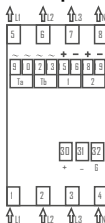

- 1,2,3 :I-In  
5,6,7 :I-Out  
4 :Neutral-In  
8 :Neutral-Out  
15,16,18,19 :Pulse Output 1 & Pulse Output 2 Terminal  
9,10,12,13 :Tariff input a & Tariff input b Terminal  
30,31,32 :RS485 Terminal 30:B+,31:A-,32:G  
(in Modbus Model)  
Mbus Terminal 30:M+,31:M-  
(in Mbus model)

## 10.2. Connection for SO Output, Optional Tariff Input & RS 485

### Location of Modbus, 2 SO Outputs & 2 Tariff Inputs

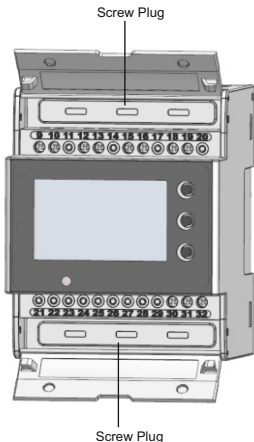
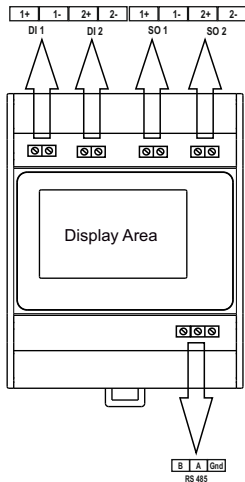

**Note : Ensure Screw Plug is inserted before connections to RS485, SO and TI is made.**

## 11. Safety Instructions :

### Warning :



This indicates potential danger that can lead to death, serious injury, or significant material damage if not followed. Ignoring these instructions can cause death, serious injury, or major material damage.

### Caution :



This indicates electric shock risk, which can also result in death, serious injury, or significant material damage. Risk of electric shock. Not taking precautions can result in death, serious injury, or major material damage.

### Qualified Personnel:

- Only qualified individuals should install and operate this device.
- Qualified personnel are those with authorization and knowledge of labeling and grounding electrical equipment according to local safety regulations.

### Intended Use:

- Use the device only as specified in the catalog and user manual.
- Use only with devices and components.

### Proper Handling:

- Ensure proper transport, storage, installation, connection, operation, and maintenance for reliable operation.
- Be aware that parts of the meter may carry dangerous voltages during use.

### Safety Precautions:

1. Use insulated tools suitable for the meter's voltages.
2. Do not connect the meter while the circuit is powered.
3. Install the meter in a dry environment within a suitable IP-rated enclosure.
4. Follow local installation codes and regulations.
5. Avoid installing in explosive areas or places with dust, mildew, or insects.
6. Use wires suitable for the meter's maximum current and ensure correct AC wire connections before powering the meter.
7. Do not touch the meter's connection clamps with bare hands or conductive materials to avoid electric shock.
8. Replace protection covers after installation.
9. Maintenance and repairs should only be performed by qualified personnel.
10. Do not break any seals on the meter as it may affect functionality, accuracy, and void the warranty.
11. Handle the meter carefully to avoid damaging internal components.
12. Ensure all clamps are properly tightened and wires fit securely to avoid bad contact and potential sparks.
13. If required clean the device with microfiber cloth, keeping liquids away from all components.

## 12. Specifications

### System :

3P4W/3P3W/1P2W programmable on site

### Measurement Parameters:

Nominal Voltage ( $U_n$ )	230 VLN (400 VLL)
Operating Voltage Range	100 - 289 VLN (173 - 500 VLL)
Power consumption in Voltage Circuit	< 2 W (10 VA) per phase
Starting Current ( $I_{st} = 0.04 \cdot I_{tr}$ )	20 mA
Minimum Current ( $I_{min} = 0.5 \cdot I_{tr}$ )	250 mA
Transitional Current ( $I_{tr}$ )	0.5 A
Nominal Current ( $I_n = 10 \cdot I_{tr}$ )	5 A
Maximum Current ( $I_{max} = 200 \cdot I_{tr}$ )	100 A
Operating Current Range	0.25-5 A (100 A)
Short time Over-current	$30 \cdot I_{max}$ for half-cycle at 50 Hz
Power consumption in Current Circuit	<1VA per phase
Nominal Frequency	50 Hz
Operating Frequency Range	49 Hz To 51 Hz

### Auxiliary Supply :

Type Self Powered

### Reference Conditions for Accuracy :

Reference Temperature	23°C ± 2°C
Input Voltage	$U_n \pm 1\%$
Input Waveform	Sinusoidal (distortion factor <2%)
Input Frequency	50 Hz ± 0.3%

### Accuracy :

Active Energy (Import/Export)	Class B as per EN50470-3 Class 1 as per IEC 62053-21
Reactive Energy (Import/Export)	± 2.0 %
Apparent Energy	± 1.0 %
Voltage	± 0.5% of range max

Current	± 0.5% of Nominal value
Frequency	± 0.2% of Mid frequency
Active Power	± 1% of range max
Reactive Power	± 1% of range max
Apparent Power	± 1% of range max
Power Factor	±1% of unity
VTHD and ITHD	±4% (THD>=15%)

#### **Pulse Outputs :**

SO1 and SO2	Passive Opto-isolated
Contact Ranges	5-27V DC, 27 mA DC (max)
Pulse Duration	60, 100, 200 millisecond
Pulse Rate	0.01, 0.1, 1, 10, 100, 500 & 1000 pulse per kWh and kVARh
Parameters	Total/Import/Export kWh and kVARh

#### **Impulse LED :**

Impulse Rate	1000 pulse per kWh
--------------	--------------------

#### **Communication Interface :**

##### **MODBUS :**

Protocol	RS485 MODBUS
Baud rate	4.8 / 9.6 /19.2/38.4/57.6 kbps
Data Width	8
Parity- Stop Bits	None -1 / None -2/ Even -1 / Odd -1
Device Address	1- 247
Response Time	200 millisecond at 9.6 kbps Baudrate

##### **MBUS :**

Protocol	EN13757-3 MBUS
Baudrate	0.3/ 0.6/ 1.2/ 2.4/ 4.8/ 9.6 kbps
Data Width	8
Parity - Stop Bits	Even -1
Device Address	1- 250

**Display Ranges :**

Active Energy	0-999999.99 kWh
Reactive Energy	0-999999.99 kVARh
Apparent Energy	0-999999.99 kVAh
Active Power	0-99999 W
Reactive Power	0-99999 VAR
Apparent Power	0-99999 VA

**Tariff Input :**

0 V	Low
230 V	High

**Installation :**

Installation	Indoor
Enclosure	IP51 (front side) IP20 (Terminal Side) (IEC 60529:2001)  (The device should only be mounted within an external enclosure, such as a meter or switch cabinet. This enclosure must offer a minimum of IP 51 protection and should be situated indoors. Only under these conditions protection against dust and water penetration assured in compliance with the IEC 62052-11. )

Housing	(4 Module DIN 43880)
Dimensions	72 mm X 90 mm X 65 mm
Weight	350 gm
Mounting	Snap-on 35 mm DIN Rail

**Safety :**

Safety Standard	According to 62052-31:2015
Installation Category	III
Protective Class	II
Pollution Degree	2
AC Voltage Test	4 kV 50 Hz for 1 minute between all electrical circuits
Impulse Voltage Withstand	6 kV (1.2 microsecond waveform)
Housing flame resistance	Flammability Class V-0 acc to UL-94, Self-extinguishing, Non-Dripping, Free of Halogen

70

**Environmental Conditions :**

Mechanical Environment	M1
Electromagnetic Environment	E2
Operating Temperature	-25°C to +55°C
Storage/Transport Temperature	-40°C to +70°C
Relative Humidity	0... 95% (Non Condensing)
Altitude	< 2000 m

**Wiring Guidelines :**

Current Input Wire Size	6 to 25 mm <sup>2</sup>
Current/Voltage Tightening Torque	2.5 - 3.0 Nm
RS485/MBUS/SO/DI Wire Size	0.1 to 2.5 mm <sup>2</sup> (Solid/Stranded with pin type lug)
RS485/MBUS/SO/Tariff Input Tightening Torque	0.4 Nm

\*\*\*\*\*



Refer to manual



Danger of electric shock



Do not discard

While TE has made every reasonable effort to ensure the accuracy of the information in this catalogue, TE does not guarantee that it is error-free, nor does TE make any other representation, warranty or guarantee that the information is accurate, correct, reliable or current. TE reserves the right to make any adjustments to the information contained herein at any time without notice. TE expressly disclaims all implied warranties regarding the information contained herein, including, but not limited to, any implied warranties of merchantability or fitness for a particular purpose. The dimensions in this catalogue are for reference purposes only and are subject to change without notice. Specifications are subject to change without notice. Consult TE for the latest dimensions and design specifications. TE connectivity (logo), TE (logo) and TE Connectivity are trademarks of the TE Connectivity Ltd. family of companies. Crompton is a trademark of Crompton Parkinson and is used by TE Connectivity under a licence. Other logos, product and company names mentioned herein may be trademarks of their respective owners

**TE Energy – innovative and economical solutions for the electrical power industry: cable accessories, connectors & fittings, insulators & insulation, surge arresters, switching equipment, street lighting, power measurement and control.**

### **Tyco Electronics UK Ltd**

© 2024 TE Connectivity. All Rights Reserved. PII-4537-10/25-DDR

TE Energy

Freebournes Road

Witham, Essex CM8 3AH

Phone: +44 (0)870 870 7500

Fax: +44 (0)870 240 5289

Email: [Crompton.info@te.com](mailto:Crompton.info@te.com)

[www.crompton-instruments.com](http://www.crompton-instruments.com)

