



Setup and Operation Guide

Integra 1221

Panel Mounted Energy Meter for Single and Three Phase Electrical Systems

Warnings ⚡ ⚠ Caution: Risk of Electric Shock

- During normal operation, voltages hazardous to life may be present at some of the terminals of this unit.
- At voltages below that specified in the Range of Use the meter may shut down. However, voltages hazardous to life may still be present at some of the terminals of this unit.
- Installation and servicing should be performed only by qualified, properly trained personnel abiding by local regulations.
- Ensure all supplies are de-energised before attempting connection or other procedures.
- Terminals should not be user accessible after installation and external installation provisions must be sufficient to prevent hazards under fault conditions.
- This unit is not intended to function as part of a system providing the sole means of fault protection - good engineering practice dictates that any critical function be protected by at least two independent and diverse means.
- The unit does not have internal fuses therefore external fuses must be used for protection and safety under fault conditions.
- Never open-circuit the secondary winding of an energized current transformer.
- If this equipment is used in a manner not specified by the manufacturer, protection provided by the equipment may be impaired.

1 Introduction

This document provides operating, maintenance and installation instructions. This unit measures and displays the characteristics of Single Phase Two Wire (1P2W), Three Phase Three Wire (3P3W) (Auxiliary model) and Three Phase Four Wire (3P4W) networks. The measuring parameters include voltage (V), current (A), frequency (Hz), power (kW/KVA/KVAh), power factor (PF), imported, exported and total energy (kWh/kVAh). The unit also measures maximum demand current and power, this is measured over pre-set periods of up to 60 minutes. This particular model accommodates 100mA RJ12 connected CT and can be configured to work with a wide range of CTs. It also comes with a complete communications capability with built in RS485 Modbus RTU outputs, configuration is password protected. This product is available in an auxiliary version (powered from a separate auxiliary) or a self-powered version (self-powered from any phase of the supply).

1.1 Unit Characteristics

The Integra 1221 can measure and display:

- Phase to neutral voltage and THD% (Total Harmonic Distortion) of all phases
- Line frequency
- Current, maximum demand current and current THD% of all phases
- Power, maximum power demand and power factor
- Imported, exported & total active energy
- Imported, exported & total reactive energy

The unit has a password-protected setup menu for:

- Changing the password
- System configuration - 1P2W, 3P3W (Auxiliary model), 3P4W.
- Demands integration time (DIT)
- Reset for max demand measurements

1.2 Current Transformer Primary Current

This unit requires configuring to operate with the appropriate current transformer(s), (100mA secondary). It is programmed by inputting the CT Primary value. It can be used on primary currents up to 9999A. e.g. for a 250/0.1A Pri (A) = 0250

1.3 RS485 Serial – Modbus RTU

This unit is compatible with remote monitoring through RS485 Modbus RTU. Setup screens are provided for configuring the RS485 port.

1.4 Pulsed Outputs (Self-Powered version only)

The Integra 1221 has two pulsed outputs. One pulsed output is configurable to active (Wh) or reactive (VArh) energy. The second pulsed output is fixed to 3200 pulses per displayed energy unit e.g. when the energy display is indicating kWh the pulsed output will produce 3200 pulses/kWh.

2 Start Up Screens

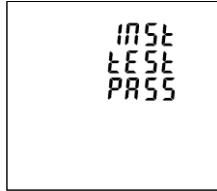
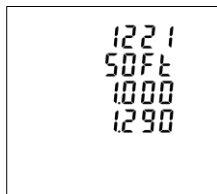
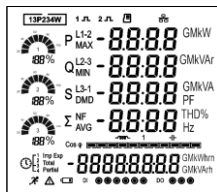
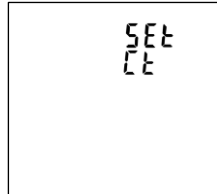

When the Instrument is first powered on, the CT ratio set up menu is presented. This simplifies installation of the product when no other changes are required. Set the required CT primary current and exit setup (see section 4.1) and the instrument will return to the default measurement screen. Note: The set CT on start up option is disabled once the primary current has been set.

The first screen lights up all display segments and can be used as a display check. The "Running Man" symbol will pulse at a rate which is controlled by the accumulation of the energy units currently shown on the display. "Warning Triangle" symbol - The 1% energy threshold is deactivated (default) – sometimes enabled to eliminate " energy creep " on Import and Export.

The second screen indicates the product number, firmware and its build number.

Please note: The numbers on the product may vary from those shown here.

The interface performs a self-test and indicates the result if the test passes.

If the test fails, the display will show 'ERR= XXXX XXXX' where the X's will identify the fault. The product will remain on this screen until the user enters the setup mode (the setup mode will operate as normal). No Input registers will be available whilst the 'ERR= XXXX XXXX' is displayed.

If the error cannot be rectified from the setup menu, it is advised to power cycle the product. If the issue remains, return the product to the factory for inspection.

*After a short delay, the meter will display the power, volts and amps screen.

3 Measurements

The buttons operate as follows:



Selects the power, voltage, current and energy display screens. In setup mode, this is "escape" (hold 3 sec) button.



Selects the voltage, current and THD display screens. In setup mode, this is the "left" (press) button.



Selects the frequency, power factor and max demand display screens. In setup mode, this is the "up" (press) button.



Selects the power (active, reactive, apparent and system) display screens. In setup mode, this is the "down" (press) button.



Selects the energy (active, reactive and total) display screens. In setup mode, this is the "right" / "enter" (press) button.

4 Setup

To enter setup mode, hold the button for 3 seconds, until the password screen appears.

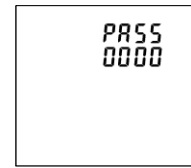

The setup is password-protected and must be entered before proceeding (default '0000').

If an incorrect password is entered, the product will exit the setup menu and return to the measurement screens.

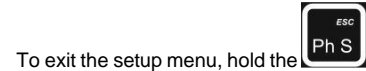

To exit the setup menu, hold the button for 3 seconds, the measurement screen will display.

4.1 Setup Entry Methods

Some menu items, such as password and CT, require a four-digit number entry while others, such as supply system, require selection from a range of options.

4.1.1 Menu Option Selection

1. To edit the current option, press . The current option will begin to flash.
2. Use the and buttons to scroll through the available options.
3. Press the button to confirm your selection. The word 'SET' will appear.
4. On completion of setting-up, press the button to go back to the setup menu or hold the button for 3 seconds to exit the setup menu completely.

4.1.2 Number Entry Procedure

When setting up the unit, some screens require the entering of a number. In particular, on entry to the setup menu, a password must be entered. Digits are set individually from left to right. The procedure is as follows:

1. The current digit to be set flashes and then can be adjusted using the and buttons.
2. Press the button to move right to the next digit.
3. After setting the last digit, press the button to save your selection. The word 'SET' will appear underneath as confirmation.

5 Setup Menu Structure

Change Password (CHng PASS)

Set a new four-digit password for the meter

System Type (SyS 3P4)

Use this section to set the type of electrical system (default setting is 3 Phase 4 Wire - 3P4). Available options: 3P4 / 1P2 3P3 (Auxiliary model only).

Voltage Transformer Primary Voltage, (Pri 277.0 V)

The 'Pri (V)' menu enables the user to set the primary voltage (10V – 999 kV) of the voltage transformer (PT) that may be connected to the meter. In 3 wire mode voltages are entered L-L and in 4 wire mode voltages are entered L-N.

Voltage Transformer Secondary Voltage, (SEC 277.0 V)

The 'SEC (V)' option enables the user to set the secondary voltage between 140 – 277V AC. In 3 wire mode voltages are entered L-L and in 4 wire mode voltages are entered L-N.

Note: The unit can measure from 57.7V AC L-N (Auxiliary model) and from 100-277V AC (Self-powered model).

Current Transformer Primary Current, (Pri 0005 A)

Set maximum primary current that can be monitored according to CT in use (1A to 9999A).

Current Transformer Secondary Current, (SEC 0.1 A)

This is set to 0.1A.

Incomer Entry (Ct Entr BOT)

The meter is capable of two operating modes. Top Entry when the incoming cable is from the top. Bottom Entry when the incoming cable is from the bottom. BOT for bottom entry - TOP for top entry. Select either BOT or TOP on each meter according to the orientation

of the line phases. Selections BOT or TOP will automatically switch L1 to L3 (Top) or L3 to L1 (BOT) - See diagram for example

Current Transformer Label

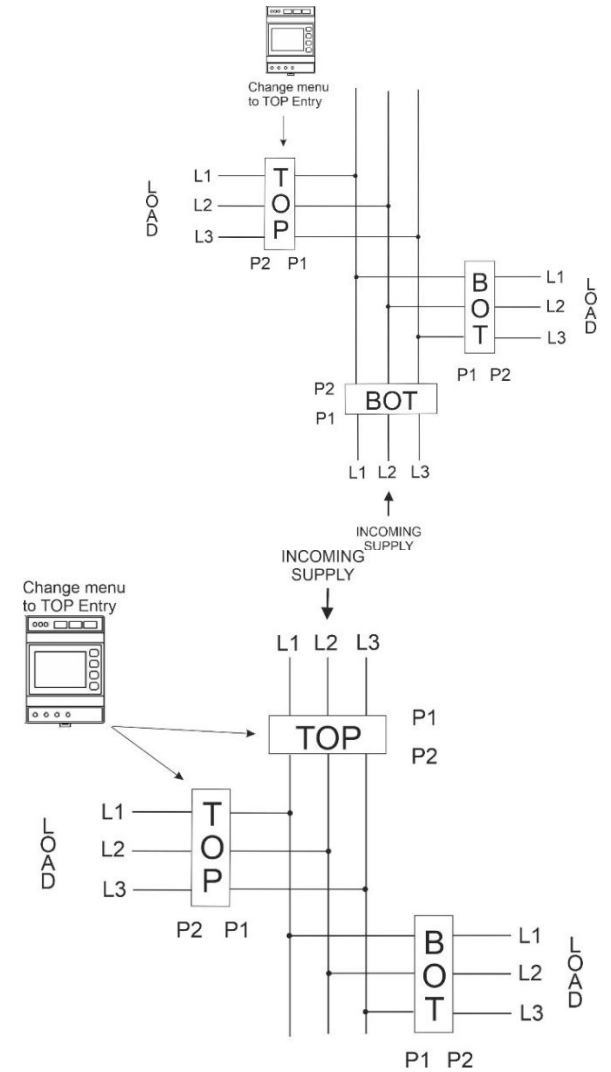
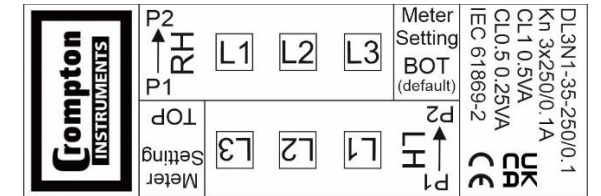

Demands Integration Time (dIt 30)

This sets the period (in minutes) in which the current and power readings are integrated for maximum demand measurement. Available options: 8/15/20/30/60

Energy Units Selection

The 'EnrG Unit' menu enables the user to set the energy units used by the meter. Available options: 10E0 (None) 10E3 (Kilo) and 10E6 (Mega) 10E9 (Giga).

Energy Low Power Limit (EnrG FLor On)

To prevent creep caused by electrical noise being accumulated as energy, the product will employ a low power limit, below which energy will not be accumulated. Available options: On/Off

Reset (rSEt ----)

The meter provides a function to reset the maximum demand value of current and power. Available options: dEd (max demand) / ALL / Energy

Comms (COmS)

Set Baud Rate: 4800/9600/19200/384000
Set Parity: none/E (even)/odd
Set Stop Bits: 1/2
Set Address: 001-247

Relay (rLy ----) (Self Powered version only)

Relay 1 – Available options: Off/37 (Imp Wh)/38 (Exp Wh)/39 (Imp VArh)/40 (Exp VArh)/41 (Exp VAh)
Pulse Duration – Available options: 200, 100 or 60mS.
Pulse settings: 1 Pulse per selected energy unit times following unit multipliers: 0.001 / 0.01 / 0.1 / 10 / 100 / 1K
Note: There are limitations that need to be factored in when setting the pulsed output. This is based upon the relay output only being able to pulse 2 times per second.

Backlight Timeout (bAc 10)

Programmable time that the backlight will remain on for before it is extinguished. Available options: Off/10/30/60/120

Test (tESt)

Test to check the display segments. Available options: Disp On (all segments will light up simultaneously)/Disp Togl (half of the segments will light up in one screen and the rest in another. The meter will continuously switch between the two for visual checks).

Product software

Details product code and firmware version.

Default Frequency (dFit 50)

Available options 50 or 60.

6 Specifications

6.1 Measured Parameters

The unit can monitor and display the following parameters of a Single Phase Two Wire (1P2W), Three Phase Three Wire (3P3W) (Auxiliary model only) or Three Phase Four Wire (3P4W) system.

6.1.1 Voltage and Current

- Phase to neutral voltages 57.7-277V AC (L-N) (Auxiliary Powered only)
- Phase to neutral voltages 100-277V AC (L-N) (Self-Powered only)
- Phase to phase voltages 100-480V AC (L-L) (Auxiliary Powered only)
- Phase to phase voltages 173-480V AC (L-L) (Self-Powered only)
- Percentage total voltage harmonic distortion (V %THD) for each phase to neutral (not for 3P3W supplies).
- Percentage total voltage harmonic distortion (V% THD) for L1-2, L2-3, L3-1 (3P3W supplies).
- Current %THD for each Phase.
- Burden <6VA
- Auxiliary version: Auxiliary powered 100 to 250 VAC ±20%, at 45 to 66Hz or 100 to 250 VDC ±20%.
- Self-powered version: Self powered from any phase and neutral (in 3P4W mode only)

6.1.2 Power factor and Frequency and Max. Demand

- Frequency in Hz
- Instantaneous power:
- Power 0-3600 MW
- Reactive power 0-3600 MVAR
- Volt-amps 0-3600 MVA
- Maximum Demand Power since last reset
- Power factor
- Maximum Neutral Demand Current, since the last reset (for 3P4W supplies only)

6.1.3 Energy Measurements

- Imported/Exported active energy 0 to 9999999.9 kWh
- Imported/Exported reactive energy 0 to 9999999.9 kVAh
- Total active energy 0 to 9999999.9 kWh
- Total reactive energy 0 to 9999999.9 kVAh

6.2 Measured Inputs

Voltage inputs through 4-way fixed connector with 2.5mm² stranded wire capacity. Single Phase Two Wire (1P2W), Three Phase Three Wire (3P3W) or Three Phase Four Wire (3P4W) unbalanced. Line frequency measured from L1 Voltage or L3 Voltage. Three current inputs via RJ12 connector.

6.3 Accuracy

- Voltage ±(0.4% of Reading + 0.1% of Range Maximum)
- Current ±(0.4% of Reading + 0.1% of nominal)
- Frequency ±0.2% of mid-frequency
- Power factor ±1% of unity (0.01)
- Active power (W) ±(0.4% of Reading + 0.1% of Range Maximum)
- Reactive power (VAR) ±(0.4% of Reading + 0.1% of Range Maximum)
- Apparent power (VA) ±(0.4% of Reading + 0.1% of Range Maximum)
- Active energy (Wh) Class 0.5S IEC 62053-22
- Reactive energy (VARh) Class 0.5S IEC 62053-24
- Total harmonic distortion 2%, up to 63rd harmonic

6.4 Auxiliary Supply (Auxiliary version only)

Auxiliary version: Three-way plug and socket connector with 2.5mm² stranded wire capacity. 100 to 250 VAC ±20%, at 45 to 66Hz or 100 to 250 VDC ±20%. Consumption <6VA

The auxiliary may be powered from the signal source, providing the source remains within tolerance of the auxiliary range.

Self-powered version: This product is self-powered from any of the three phases and neutral.

6.5 Interfaces for External Monitoring

Self-powered version: The following interfaces are provided:

- Pulse output 1 indicating real-time measured energy (configurable)
- Pulse output 2 3200 pulses/energy unit (not configurable). Only valid for 1:1 or 5:5 CT ratios only.

Self-powered and Auxiliary versions: The Modbus configuration (baud rate etc.) assignments are configured through the setup screens.

6.5.1 Pulse Output (Self-Powered version only)

Opto-coupler with potential free SPST-NO Contact

•Pulse Output-1: Contact rating 250V AC, 50mA max

•Pulse Output-2: Contact rating 70V DC, 27mA max

The two pulsed outputs use a common (-) negative terminal.

The pulse output can be set to generate pulses to represent kWh or kVAh.

Rate can be set to generate 1 pulse per selected energy unit times following unit multipliers

- 0.001
- 0.01
- 0.1
- 1
- 10
- 100
- 1000

The number selected is representative of the selected energy units, i.e., when MWh is selected the number 10 will be 10MWh, when kWh is selected the number 10 will be 10kWh etc

Pulse width 200/100/60 milliseconds.

6.5.2 RS485 Output for Modbus RTU

For Modbus RTU, the following RS485 communication parameters can be configured from the setup menu:

Baud rate: 4800/9600/19200/384000

Parity: none (default)/even/odd

Stop bits: 1 or 2

RS485 Network Address: 3 digit number - 001-247

Modbus™ Word order Hi/Lo byte order is set automatically to normal and cannot be configured from the setup menu.

6.6 Reference Conditions of Influence Quantities

Influence Quantities are variables that affect measurement errors to a minor degree. Accuracy is verified under nominal value (within the specified tolerance) of these conditions.

- Ambient temperature 23°C ±1°C
- Input waveform 50 or 60Hz ±2%
- Input waveform Sinusoidal (distortion factor < 0.005)
- Magnetic field of external origin Terrestrial flux

Auxiliary product (additional reference conditions):

- Auxiliary supply voltage Nominal ±1%
- Auxiliary supply frequency Nominal ±1%
- Auxiliary supply waveform (if AC) Sinusoidal (distortion factor < 0.05)

6.7 Environment

- Operating temperature -25°C to +70°C*
- Storage temperature -40°C to +70°C*
- Relative humidity 0 to 90%, non-condensing
- Altitude Up to 2000m
- Warm up time 1 minute
- Vibration 10Hz to 50Hz, IEC 60068-2-6, 2g
- Shock 30g in 3 planes

*Maximum operating and storage temperatures are in the context of typical daily and seasonal variation.

6.8 Mechanics

- Enclosure Style DIN 96 panel mount
- Dimensions 96x96x (52 mm rear of panel)
- Panel cut-out 92x92mm
- Panel thickness 1-5 mm
- Protection rating Front IP54, Rear IP30, IP64 with additional kit
- Material UL 94-VO
- Weight 340 g

7 Installation and Maintenance

7.1 Installation notes

Units should be installed in a dry position, where the ambient temperature is reasonably stable and will not be outside the range -25 to +70°C.

Vibration should be kept to a minimum.

Preferably, mount the Integra so that the display contrast is not reduced by direct sunlight or other high intensity lighting.

7.2 Input Wiring and Fusing (Auxiliary version only)

Voltage lines must be fused with a fast blow AC fuse 1A maximum. Choose fuses of a type and with a breaking capacity appropriate to the supply and in accordance with local regulations.

A switch or circuit breaker allowing isolation of supplies to the unit must be provided.

7.3 Wire Size

Voltage terminal blocks will accept 0.5mm² to 2.5mm² stranded cable.

7.4 Maintenance

The front of the case should be wiped with a dry cloth only, using minimal pressure. If necessary wipe the rear case with a dry cloth.

No user serviceable parts.

8 Dimensions

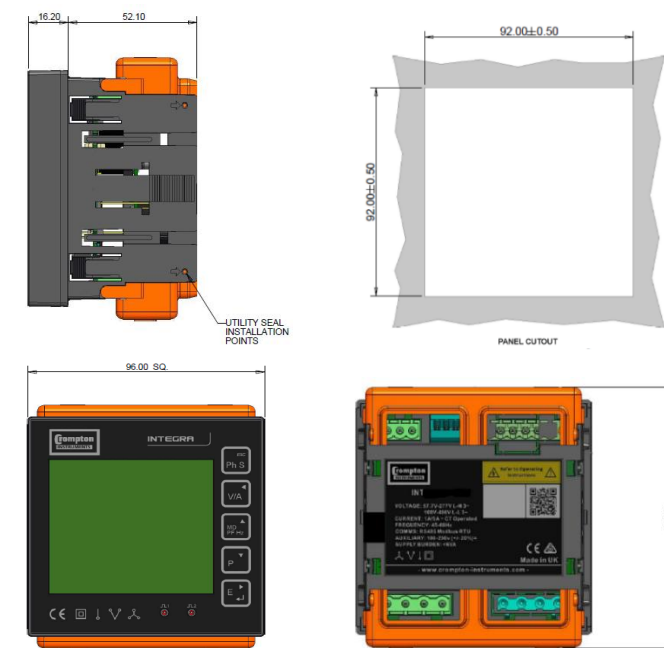

9 Installation

9.1 RS485 Serial – Modbus RTU

Screened twisted pair cable should be used. For longer cable runs or noisier environments, use of a cable specifically designed for RS485 may be necessary to achieve optimum performance. All "A" terminals should be connected together using one conductor of the twisted pair cable, all "B" terminals should be connected together using the other conductor in the pair. The cable screen should be connected to the "Gnd" terminals.

A Belden 9841 (Single pair) or 9842 (Two pair) or similar cable with a characteristic impedance of 120 ohms is recommended. The cable should be terminated at each end with a 120 ohm, quarter watt (or greater) resistor.

For further information please refer to CI-3L12002 communications guide.

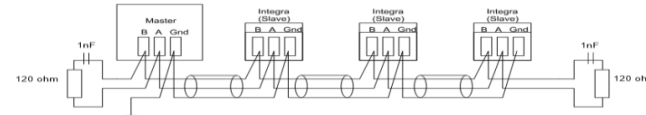

9.2 Modbus node ID



To quickly view the Modbus node ID without entering the full set up menu, press and hold buttons P & E.

9.3 Self-powered/Auxiliary Connection Diagrams

9.3.1 Single phase two wires

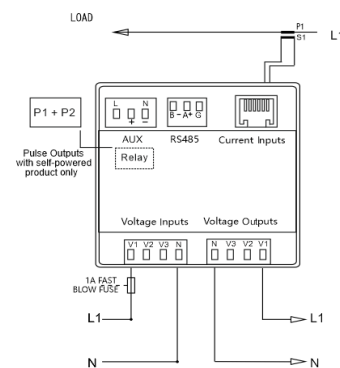

9.3.2 Three phase three wires (Auxiliary version only)

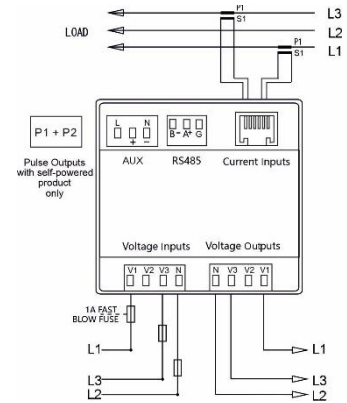

Please note for 3P3W configuration L2 is connected through the neutral and not V2.

9.3.3 Three phase four wires

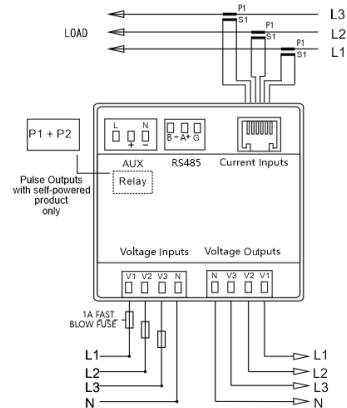

A maximum of 20 additional instruments can be connected in a single chain, using the voltage INPUT / OUTPUT terminals.

Explanation of Symbols



Refer to manual



Danger of electric shock



While TE has made every reasonable effort to ensure the accuracy of the information in this catalogue, TE does not guarantee that it is error-free, nor does TE make any other representation, warranty or guarantee that the information is accurate, correct, reliable or current. TE reserves the right to make any adjustments to the information contained herein at any time without notice. TE expressly disclaims all implied warranties regarding the information contained herein, including, but not limited to, any implied warranties of merchantability or fitness for a particular purpose. The dimensions in this catalogue are for reference purposes only and are subject to change without notice. Specifications are subject to change without notice. Consult TE for the latest dimensions and design specifications. TE connectivity (logo), TE (logo) and TE Connectivity are trademarks of the TE Connectivity Ltd. family of companies. Crompton is a trademark of Crompton Parkinson and is used by TE Connectivity under a licence. Other logos, product and company names mentioned herein may be trademarks of their respective owners

TE Energy – innovative and economical solutions for the electrical power industry: cable accessories, connectors & fittings, insulators & insulation, surge arresters, switching equipment, street lighting, power measurement and control.

Tyco Electronics UK Ltd
TE Energy
Freebournes Road
Witham, Essex CM8 3AH
Phone: +44 (0)870 870 7500
Fax: +44 (0)870 240 5289
Email: crompton.info@te.com
www.crompton-instruments.com



Project 2277. Drawing No. CI-3L37801
Rev.05 17/06/2026